

DATE	NO.	DESCRIPTION	BY	PROJECT NAME	UNO
5/12/09	△	For Approval	TMAC	LITITZ W.W.T.P.	UNO
6/04/09	△	For Approval	TMAC	WARWICK TWP.-LANCASTER CO., PA	UNO
10/02/09	△	For Approval	TMAC	PLEASANT MOUNT WELDING, INC.	UNO
10/16/09	△	For Fabrication - Customer Changes	MT	ENTECH ENGINEERING,	UNO
10/20/09	△	For Fabrication - Corrected RF Marks	MT		UNO

STEEL ASTM	A992	UNO	PROJECT NAME	UNO
ELECTRODES	E70xx LH	UNO	LITITZ W.W.T.P.	UNO
WELDS	1/4 BUTT/FILLET	UNO	WARWICK TWP.-LANCASTER CO., PA	UNO
OPEN HOLES	13/16"	UNO	PLEASANT MOUNT WELDING, INC.	UNO
BOLTS	3/4" A325-N-ST	UNO	ENTECH ENGINEERING,	UNO
PAINT	PER SPECS	UNO		UNO

DESCRIPTION	DATE	JOB No.
CENTRIFUGE & BIOSOLIDS DRYER BLDG. STR.	05/12/2009	17-052-9
	DRAWN BY	DRG No.
	TMAC	E3-1



L9X4X1/2 x 4 SHOP OPTION  
 SUBSTITUTE BT PLATE

4	RF1
4	RF2
2	RF3
4	RF4
20	RF5
8	RF6
2	RF7
Qty.	In Assembly

44	a21	L9X4X1/2	0'-4"		A36
Qty.	Mark	Size	Length	Comments	Grade

PROJECT NAME	LITITZ W.W.T.P.
LOCATION	WARWICK TWP.-LANCASTER CO., PA
CUSTOMER	PLEASANT MOUNT WELDING, INC.
ARCHITECT	ENTECH ENGINEERING, INC.

<b>A S P Services Inc</b>		
Selinsgrove, PA 17870		
(570) 374-5333 FAX (570) 374-5335 asp-services-inc.com		
DESCRIPTION	DATE	JOB No.
ANGLE	10/02/2009	17-052-9
	DRAWN BY	DRG No.
TMAC		a21

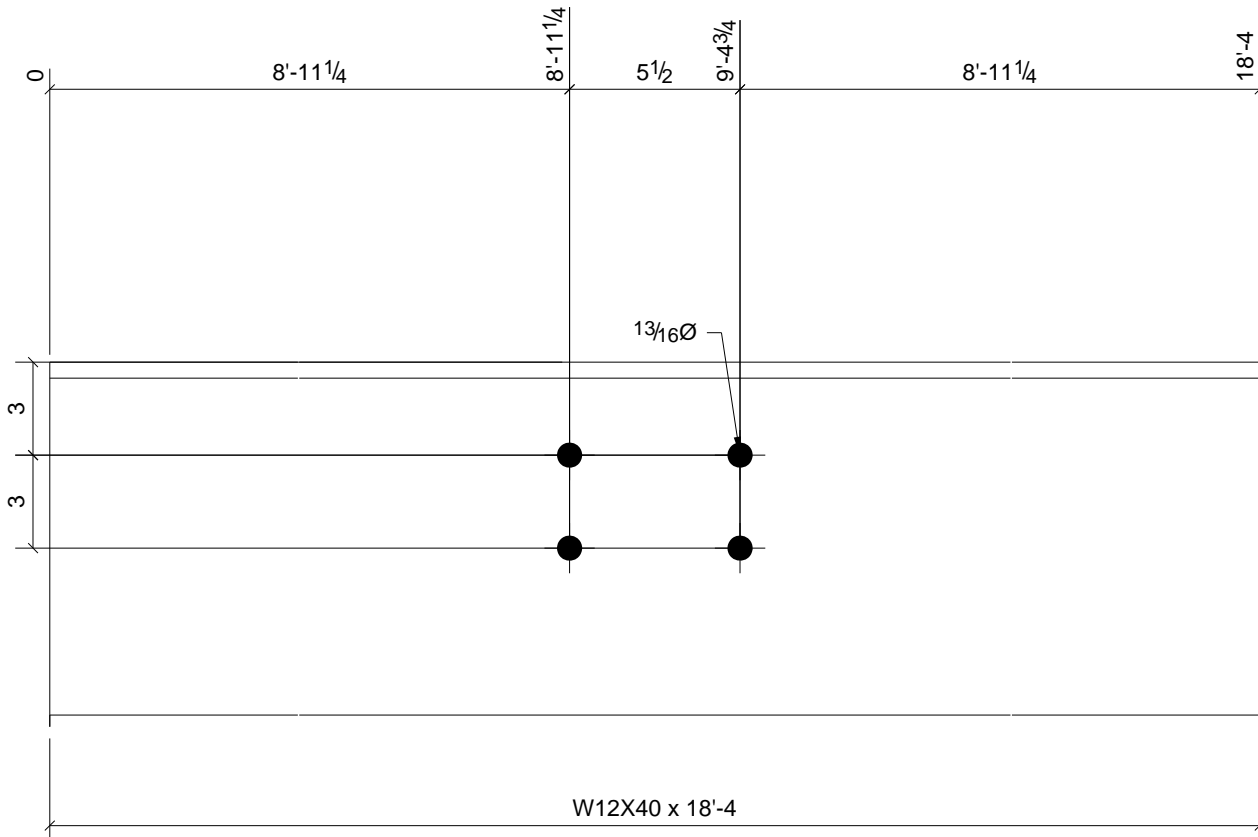

2	B2
Qty.	In Assembly

2	B2	W12X40	18'-4"		A992
Qty.	Mark	Size	Length	Comments	Grade

PROJECT NAME	LITITZ W.W.T.P.
LOCATION	WARWICK TWP.-LANCASTER CO., PA
CUSTOMER	PLEASANT MOUNT WELDING, INC.
ARCHITECT	ENTECH ENGINEERING, INC.

<b>A S P Services Inc</b>	
Selinsgrove, PA 17870	
(570) 374-5333 FAX (570) 374-5335 asp-services-inc.com	
DESCRIPTION	BEAM
DATE	10/02/2009
JOB No.	17-052-9
DRAWN BY	TMAC
DRG No.	B2



1	B25
Qty.	In Assembly

1	B25	W12X40	18'-4"		A992
Qty.	Mark	Size	Length	Comments	Grade

PROJECT NAME	LITITZ W.W.T.P.
LOCATION	WARWICK TWP.-LANCASTER CO., PA
CUSTOMER	PLEASANT MOUNT WELDING, INC.
ARCHITECT	ENTECH ENGINEERING, INC.

<b>A S P Services Inc</b>		
Selinsgrove, PA 17870		
(570) 374-5333 FAX (570) 374-5335 <a href="http://aspservicesinc.co">aspservicesinc.co</a>		
DESCRIPTION	DATE	JOB No.
BEAM	10/02/2009	17-052-9
	DRAWN BY	DRG No.
TMAC		B25

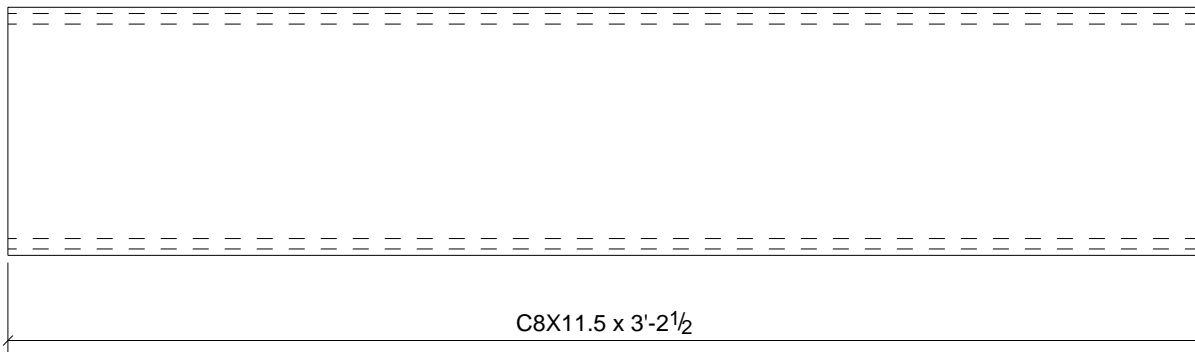

4	RF6
Qty.	In Assembly

4	c2	C8X11.5	3'-2 1/2"		A36
Qty.	Mark	Size	Length	Comments	Grade

PROJECT NAME	LITITZ W.W.T.P.
LOCATION	WARWICK TWP.-LANCASTER CO., PA
CUSTOMER	PLEASANT MOUNT WELDING, INC.
ARCHITECT	ENTECH ENGINEERING, INC.

<b>A S P Services Inc</b>		
Selinsgrove, PA 17870		
(570) 374-5333 FAX (570) 374-5335 asp-services-inc.co		
DESCRIPTION	DATE	JOB No.
CHANNEL	10/19/2009	17-052-9
	DRAWN BY	DRG No.
TMAC		c2

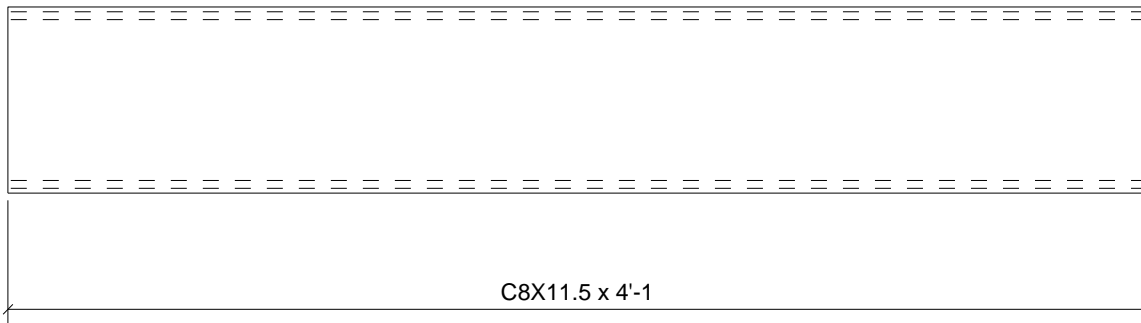

1	RF1
1	RF2
1	RF4
5	RF5
2	RF6
Qty.	In Assembly

10	c3	C8X11.5	4'-1"	A36
Qty.	Mark	Size	Length	Grade

PROJECT NAME <b>LITITZ W.W.T.P.</b>		<b>A S P Services Inc</b> Selinsgrove, PA 17870 (570) 374-5333 FAX (570) 374-5335 asp-services-inc.com		
LOCATION <b>WARWICK TWP.-LANCASTER CO., PA</b>				
CUSTOMER <b>PLEASANT MOUNT WELDING, INC.</b>		DESCRIPTION <b>CHANNEL</b>	DATE 10/19/2009	JOB No. 17-052-9
ARCHITECT <b>ENTECH ENGINEERING, INC.</b>			DRAWN BY TMAC	DRG No. c3

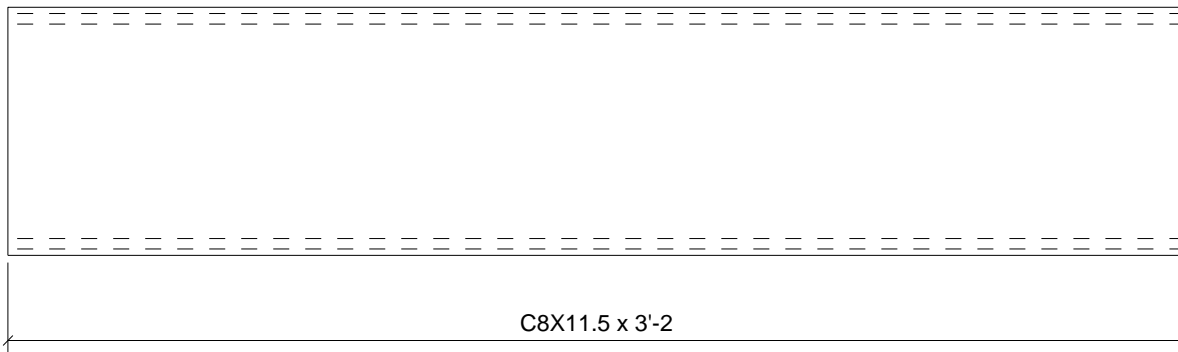

10	RF5
Qty.	In Assembly

Qty.	Mark	Size	Length	Comments	Grade
10	c4	C8X11.5	3'-2"		A36

PROJECT NAME	LITITZ W.W.T.P.
LOCATION	WARWICK TWP.-LANCASTER CO., PA
CUSTOMER	PLEASANT MOUNT WELDING, INC.
ARCHITECT	ENTECH ENGINEERING, INC.

<b>A S P Services Inc</b>		
Selinsgrove, PA 17870		
(570) 374-5333 FAX (570) 374-5335 asp-servicesinc.co		
DESCRIPTION	DATE	JOB No.
CHANNEL	10/19/2009	17-052-9
	DRAWN BY	DRG No.
	TMAC	c4

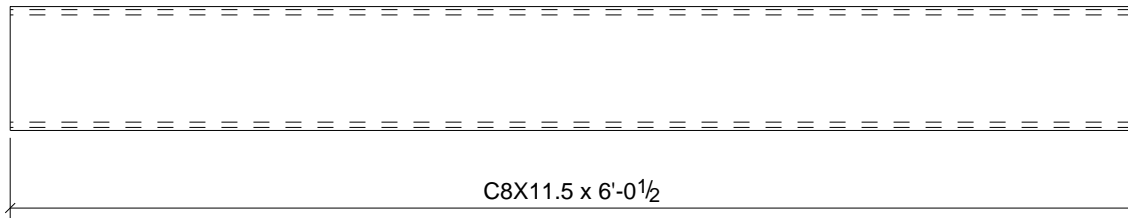

1	RF4
Qty.	In Assembly

1	c5	C8X11.5	6'-0 1/2"		A36
Qty.	Mark	Size	Length	Comments	Grade

PROJECT NAME	LITITZ W.W.T.P.
LOCATION	WARWICK TWP.-LANCASTER CO., PA
CUSTOMER	PLEASANT MOUNT WELDING, INC.
ARCHITECT	ENTECH ENGINEERING, INC.

<b>A S P Services Inc</b>		
Selinsgrove, PA 17870		
(570) 374-5333 FAX (570) 374-5335 asp-servicesinc.co		
DESCRIPTION	DATE	JOB No.
CHANNEL	10/19/2009	17-052-9
	DRAWN BY	DRG No.
	TMAC	c5



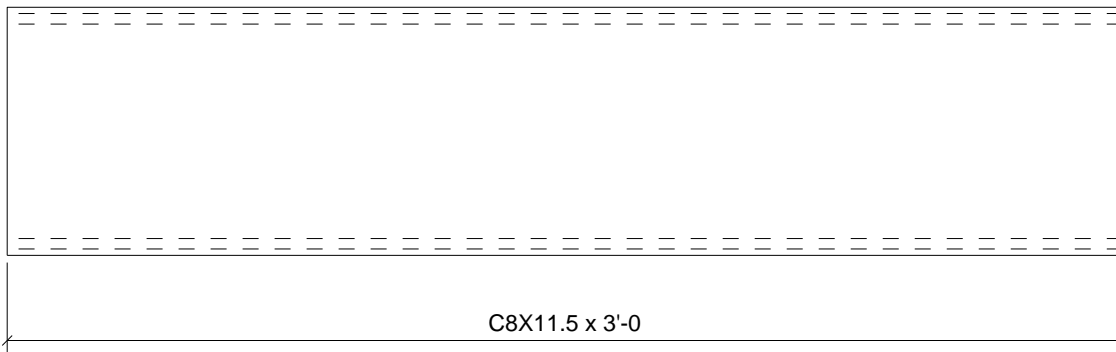

2	RF1
Qty.	In Assembly

Qty.	Mark	Size	Length	Comments	Grade
2	c6	C8X11.5	3'-0"		A36

PROJECT NAME	LITITZ W.W.T.P.
LOCATION	WARWICK TWP.-LANCASTER CO., PA
CUSTOMER	PLEASANT MOUNT WELDING, INC.
ARCHITECT	ENTECH ENGINEERING, INC.

<b>A S P Services Inc</b>		
Selinsgrove, PA 17870		
(570) 374-5333 FAX (570) 374-5335 <a href="http://aspservicesinc.co">aspservicesinc.co</a>		
DESCRIPTION	DATE	JOB No.
CHANNEL	10/19/2009	17-052-9
	DRAWN BY	DRG No.
	TMAC	c6

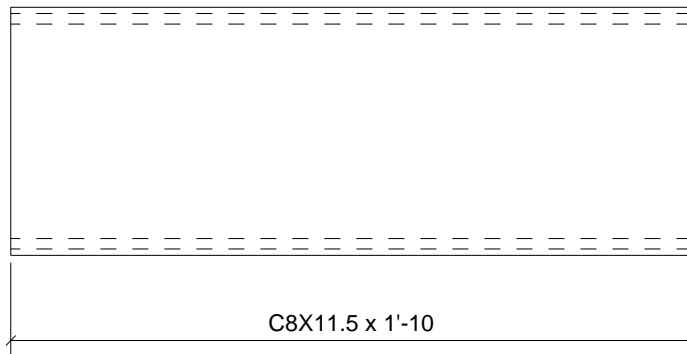

1	RF2
Qty.	In Assembly

1	c7	C8X11.5	1'-10"	A36
Qty.	Mark	Size	Length	Grade

PROJECT NAME	LITITZ W.W.T.P.
LOCATION	WARWICK TWP.-LANCASTER CO., PA
CUSTOMER	PLEASANT MOUNT WELDING, INC.
ARCHITECT	ENTECH ENGINEERING, INC.

<b>A S P Services Inc</b>		
Selinsgrove, PA 17870		
(570) 374-5333 FAX (570) 374-5335 <a href="http://aspservicesinc.co">aspservicesinc.co</a>		
DESCRIPTION	DATE	JOB No.
CHANNEL	10/19/2009	17-052-9
	DRAWN BY	DRG No.
TMAC	c7	

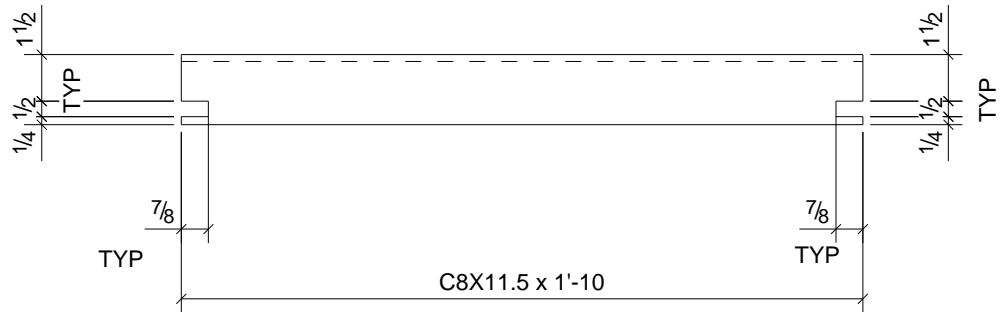

1	RF2
Qty.	In Assembly

1	c8	C8X11.5	1'-10"		A36
Qty.	Mark	Size	Length	Comments	Grade

PROJECT NAME	LITITZ W.W.T.P.
LOCATION	WARWICK TWP.-LANCASTER CO., PA
CUSTOMER	PLEASANT MOUNT WELDING, INC.
ARCHITECT	ENTECH ENGINEERING, INC.

<b>A S P Services Inc</b> Selinsgrove, PA 17870 (570) 374-5333 FAX (570) 374-5335 asp-servicesinc.co		
DESCRIPTION	DATE	JOB No.
	10/19/2009	17-052-9
CHANNEL	DRAWN BY	DRG No.
	TMAC	c8

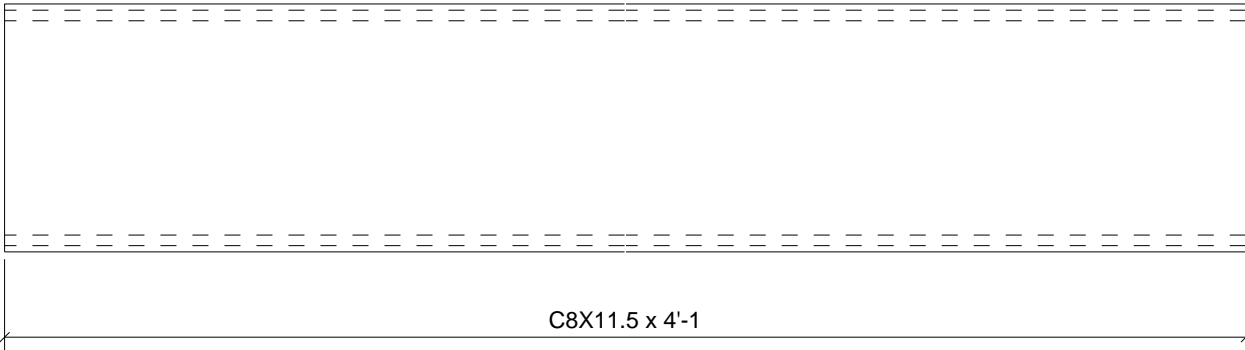

1	RF1
Qty.	In Assembly

1	RF1	C8X11.5	4'-1"		A36
Qty.	Mark	Size	Length	Comments	Grade

PROJECT NAME	LITITZ W.W.T.P.
LOCATION	WARWICK TWP.-LANCASTER CO., PA
CUSTOMER	PLEASANT MOUNT WELDING, INC.
ARCHITECT	ENTECH ENGINEERING, INC.

<b>A S P Services Inc</b>		
Selinsgrove, PA 17870		
(570) 374-5333 FAX (570) 374-5335 asp-servicesinc.co		
DESCRIPTION	DATE	JOB No.
CHANNEL	10/19/2009	17-052-9
	DRAWN BY	DRG No.
TMAC		RF1

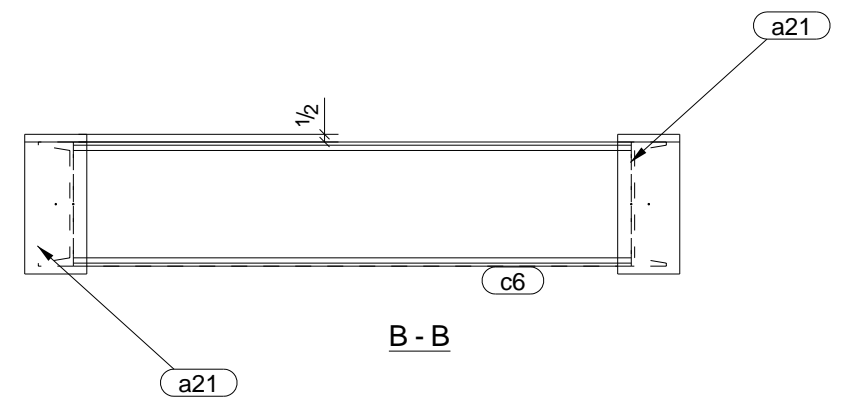
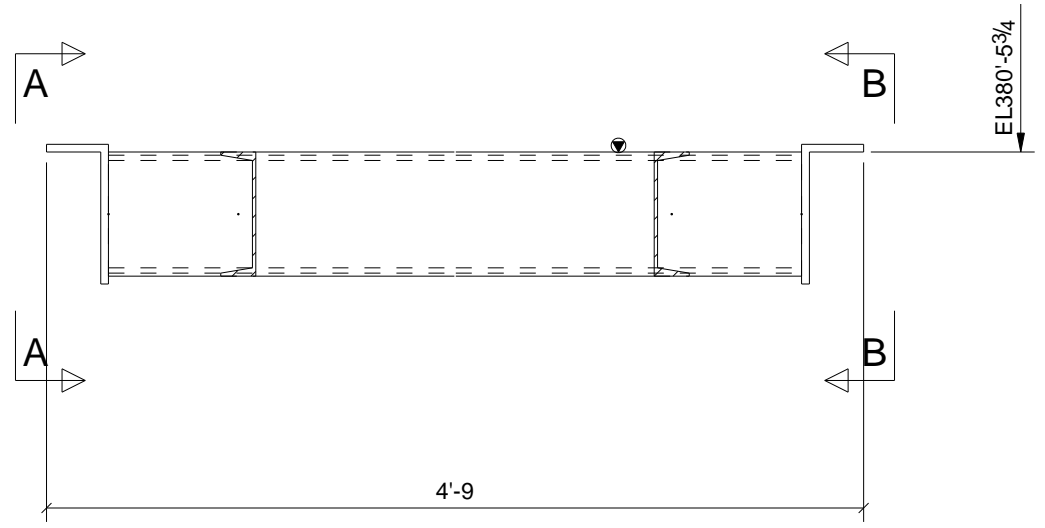
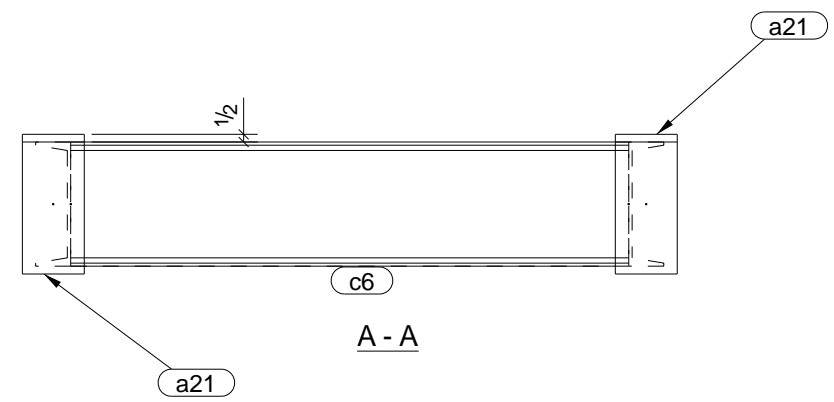
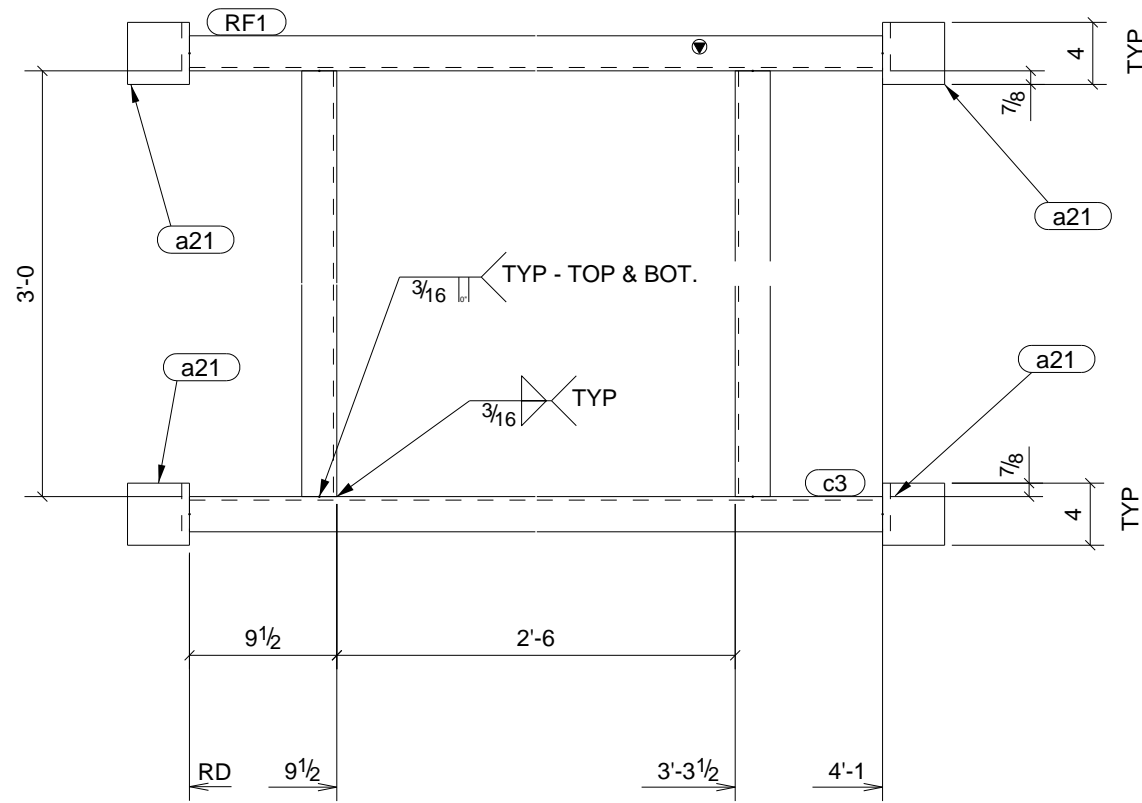

**ONE - ROOF FRAME - RF1**

**BILL OF MATERIAL**

Qty Ea.	Qty Tot	Piece Mark	Description	Length	Weight Total	Remarks	Adv Mill #	Steel Grade
	1	RF1	ROOF FRAME					
1	1		C8X11.5	4'-1"	47	SQ-2		A36
4	4	a21	L9X4X1/2	0'-4"	28			A36
1	1	c3	C8X11.5	4'-1"	47			A36
2	2	c6	C8X11.5	3'-0"	69			A36

STEEL ASTM	A992	UNO
ELECTRODES	E70xx LH	UNO
WELDS	1/4 BUTT/FILLET	UNO
OPEN HOLES	13/16"	UNO
BOLTS	3/4"Ø A325-N-ST	UNO
PAINT	PER SPECS	UNO

PROJECT NAME	LITITZ W.W.T.P.
LOCATION	WARWICK TWP.-LANCASTER CO., PA
CONTRACTOR	PLEASANT MOUNT WELDING, INC.
ARCHITECT	ENTECH ENGINEERING, INC.

10/2/09	△C	R & R For Approval	TMAC
10-19-09	△1	CORRECTED CHANNEL pc MARKS TO c	TMc
10/16/09	△0	For Fabrication - Customer Changes	MT
DATE	NO.	DESCRIPTION	BY

**A S P Services Inc**  
Selinsgrove, PA 17870  
(570) 374-5333 FAX (570) 374-5335 asp-services-inc.com

DESCRIPTION	DATE	JOB No.
ROOF FRAME ASSEMBLY	10/02/2009	17-052-9
DRAWN BY	DATE	DRG No.
TMAC		RF1

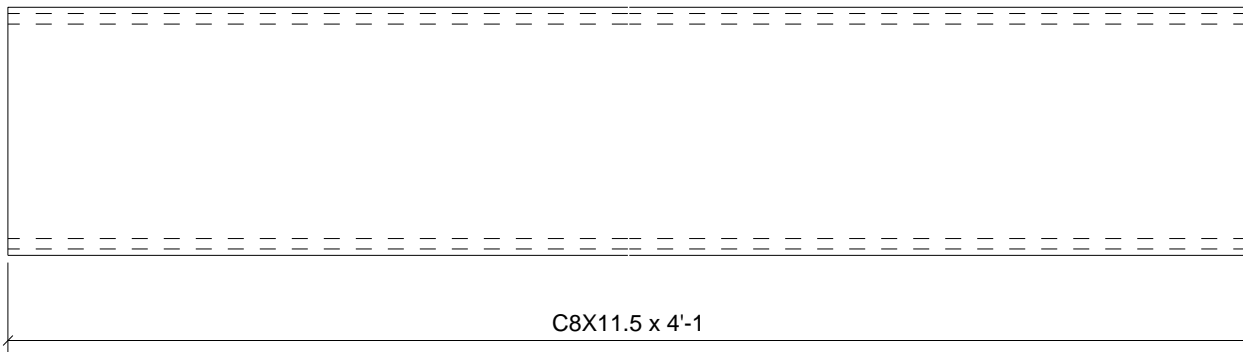

1	RF2
Qty.	In Assembly

1	RF2	C8X11.5	4'-1"	Comments	A36
Qty.	Mark	Size	Length	Comments	Grade

PROJECT NAME	LITITZ W.W.T.P.
LOCATION	WARWICK TWP.-LANCASTER CO., PA
CUSTOMER	PLEASANT MOUNT WELDING, INC.
ARCHITECT	ENTECH ENGINEERING, INC.

<b>A S P Services Inc</b>	
Selinsgrove, PA 17870	
(570) 374-5333 FAX (570) 374-5335 asp-servicesinc.co	
DESCRIPTION	CHANNEL
DATE	10/19/2009
JOB No.	17-052-9
DRAWN BY	TMAC
DRG No.	RF2

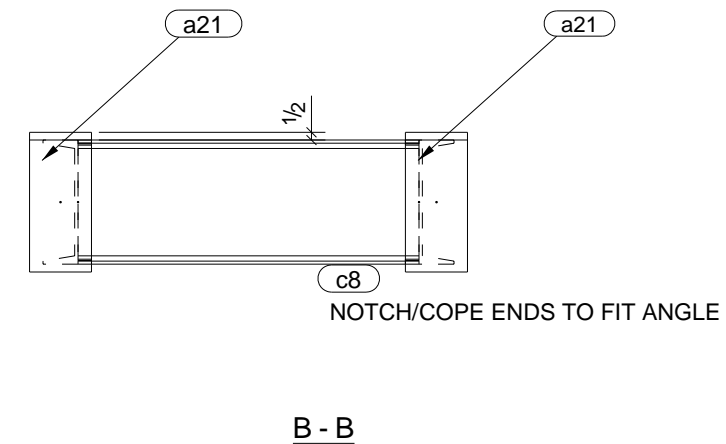
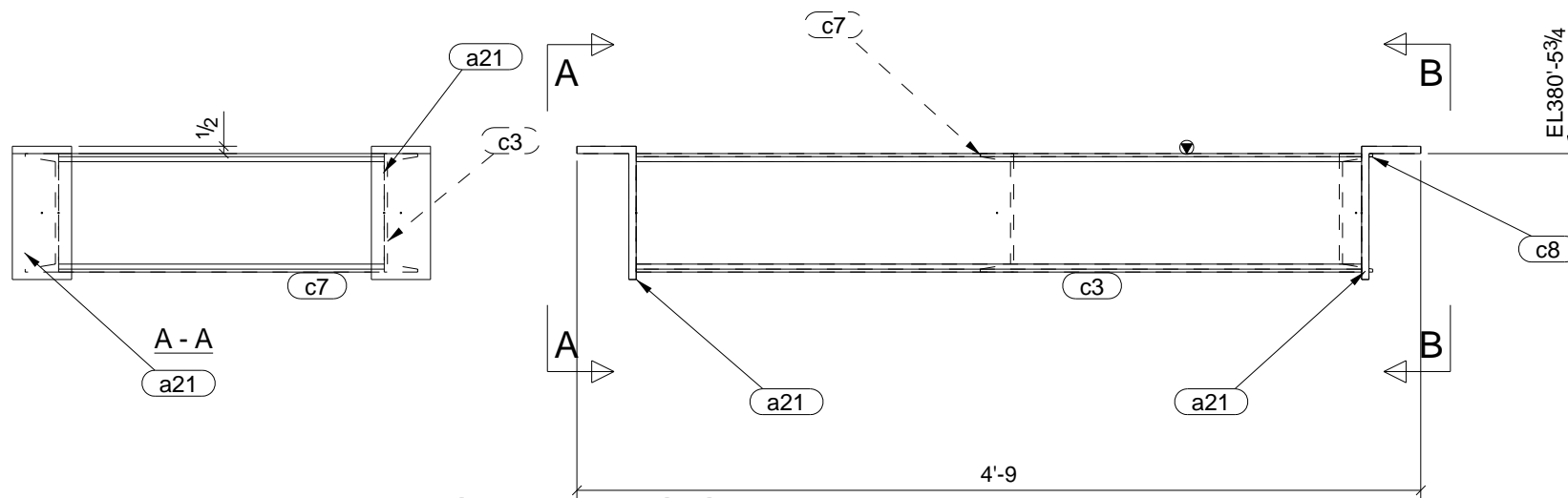
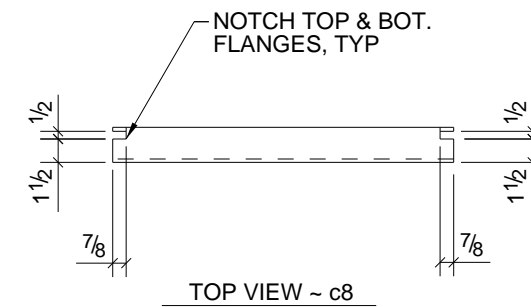
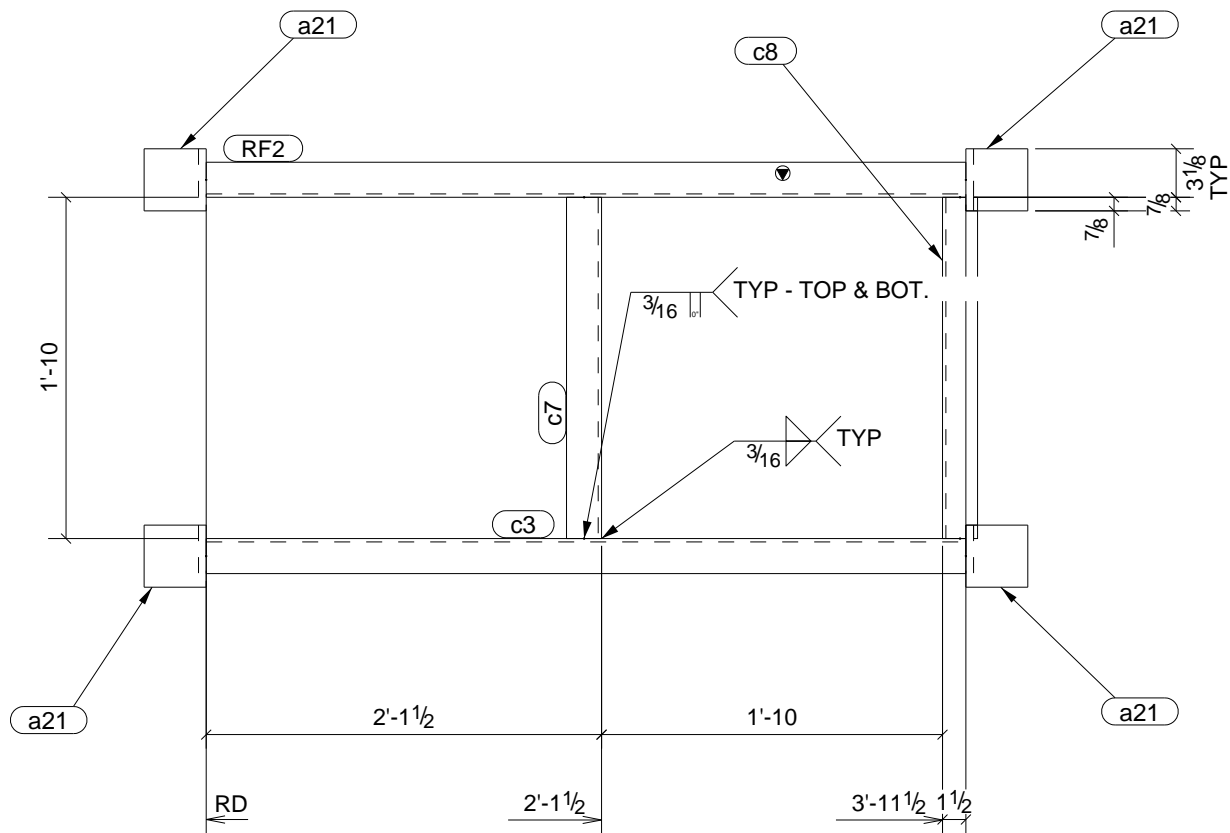

**ONE - ROOF FRAME - RF2**

**BILL OF MATERIAL**

Qty Ea.	Qty Tot	Piece Mark	Description	Length	Weight Total	Remarks	Adv Mill #	Steel Grade
	1	RF2	ROOF FRAME					
1	1		C8X11.5	4'-1"	47	SQ-2		A36
4	4	a21	L9X4X1/2	0'-4"	28			A36
1	1	c3	C8X11.5	4'-1"	47			A36
1	1	c7	C8X11.5	1'-10"	21			A36
1	1	c8	C8X11.5	1'-10"	21			A36

STEEL ASTM	A992	UNO	PROJECT NAME	LITITZ W.W.T.P.
ELECTRODES	E70xx LH	UNO	LOCATION	WARWICK TWP.-LANCASTER CO., PA
WELDS	1/4 BUTT/FILLET	UNO	CONTRACTOR	PLEASANT MOUNT WELDING, INC.
OPEN HOLES	13/16"	UNO	ARCHITECT	ENTECH ENGINEERING, INC.
BOLTS	3/4"Ø A325-N-ST	UNO		
PAINT	PER SPECS	UNO		

10/2/09	△C	R & R For Approval	TMAC
10-19-09	△1	CORRECTED CHANNEL pc MARKS TO c	TMc
10/16/09	△0	For Fabrication - Customer Changes	MT
DATE	NO.	DESCRIPTION	BY

**A S P Services Inc**  
Selinsgrove, PA 17870  
(570) 374-5333 FAX (570) 374-5335 aspservicesinc.com

DESCRIPTION	DATE	JOB No.
ROOF FRAME ASSEMBLY	10/02/2009	17-052-9
DRAWN BY	DATE	DRG No.
TMAC		RF2

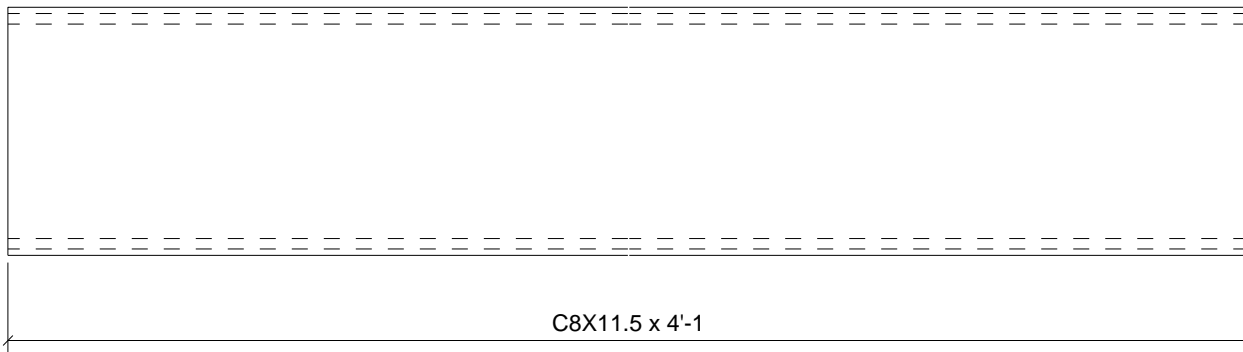

1	RF3
Qty.	In Assembly

1	RF3	C8X11.5	4'-1"	Comments	A36
Qty.	Mark	Size	Length	Comments	Grade

PROJECT NAME	LITITZ W.W.T.P.
LOCATION	WARWICK TWP.-LANCASTER CO., PA
CUSTOMER	PLEASANT MOUNT WELDING, INC.
ARCHITECT	ENTECH ENGINEERING, INC.

<b>A S P Services Inc</b>	
Selinsgrove, PA 17870	
(570) 374-5333 FAX (570) 374-5335 <a href="http://aspservicesinc.co">aspservicesinc.co</a>	
DESCRIPTION	CHANNEL
DATE	10/19/2009
JOB No.	17-052-9
DRAWN BY	TMAC
DRG No.	RF3





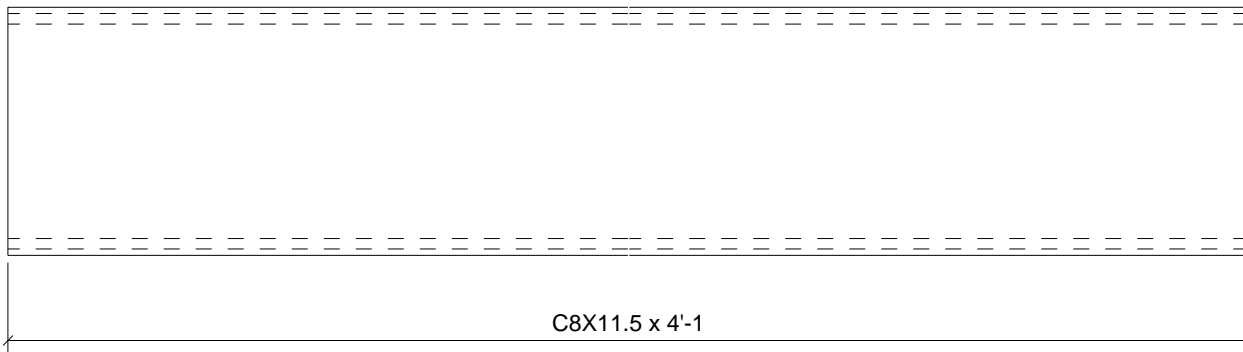

1	RF4
Qty.	In Assembly

1	RF4	C8X11.5	4'-1"	Comments	A36
Qty.	Mark	Size	Length	Comments	Grade

PROJECT NAME	LITITZ W.W.T.P.
LOCATION	WARWICK TWP.-LANCASTER CO., PA
CUSTOMER	PLEASANT MOUNT WELDING, INC.
ARCHITECT	ENTECH ENGINEERING, INC.

<b>A S P Services Inc</b>	
Selinsgrove, PA 17870	
(570) 374-5333 FAX (570) 374-5335 <a href="http://aspservicesinc.co">aspservicesinc.co</a>	
DESCRIPTION	CHANNEL
DATE	10/19/2009
JOB No.	17-052-9
DRAWN BY	TMAC
DRG No.	RF4

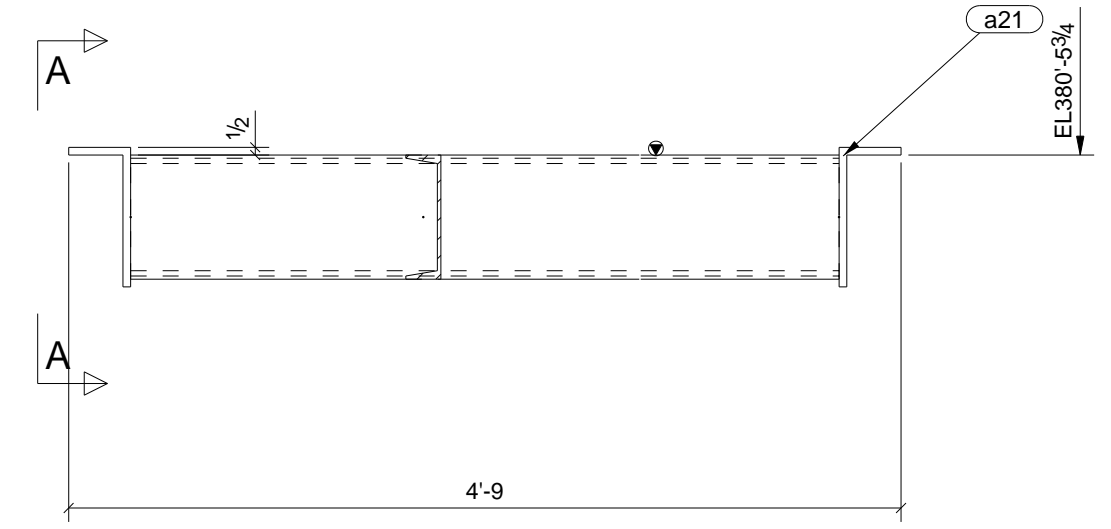
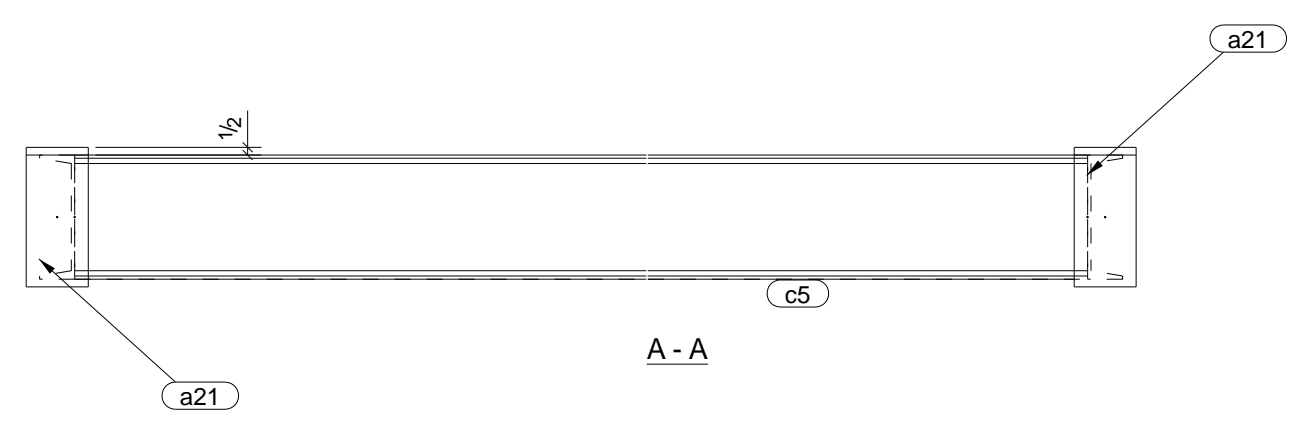
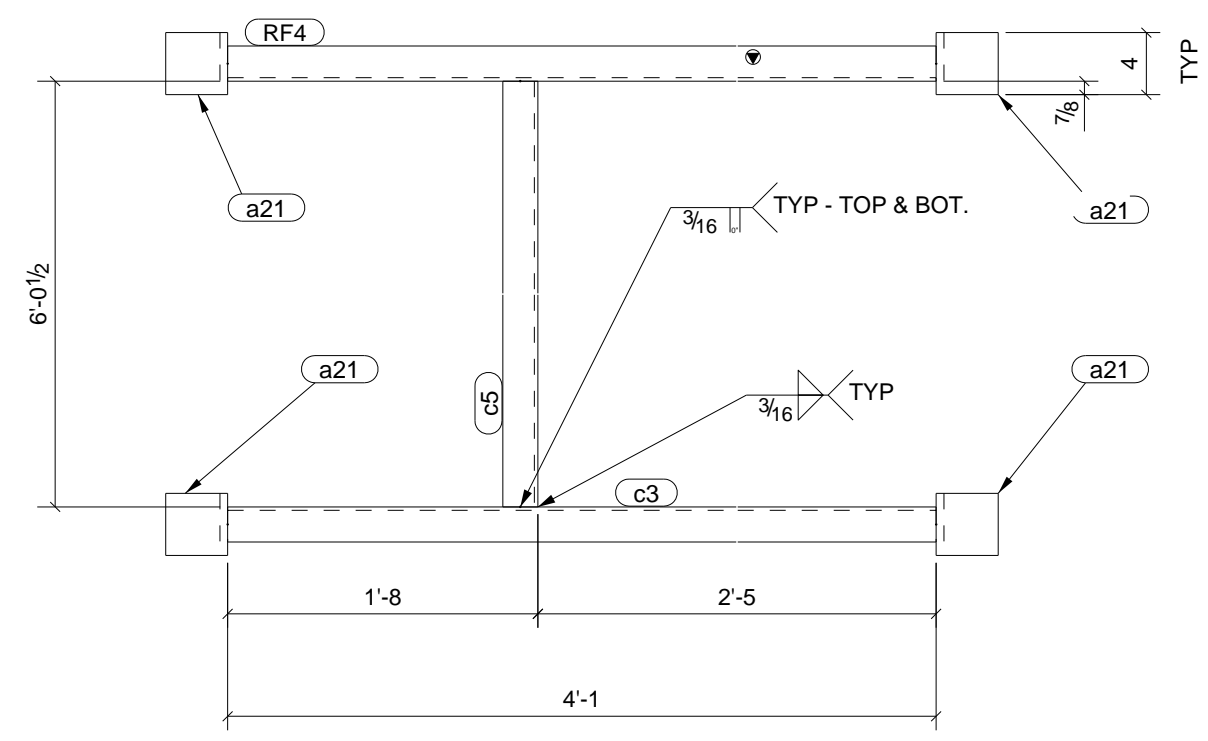

**ONE - ROOF FRAME - RF4**

**BILL OF MATERIAL**

Qty Ea.	Qty Tot	Piece Mark	Description	Length	Weight Total	Remarks	Adv Mill #	Steel Grade
	1	RF4	ROOF FRAME					
1	1		C8X11.5	4'-1"	47	SQ-2		A36
4	4	a21	L9X4X1/2	0'-4"	28			A36
1	1	c3	C8X11.5	4'-1"	47			A36
1	1	c5	C8X11.5	6'-0 1/2"	69			A36

STEEL ASTM	A992	UNO
ELECTRODES	E70xx LH	UNO
WELDS	1/4 BUTT/FILLET	UNO
OPEN HOLES	13/16"	UNO
BOLTS	3/4"Ø A325-N-ST	UNO
PAINT	PER SPECS	UNO

PROJECT NAME	LITITZ W.W.T.P.
LOCATION	WARWICK TWP.-LANCASTER CO., PA
CONTRACTOR	PLEASANT MOUNT WELDING, INC.
ARCHITECT	ENTECH ENGINEERING, INC.

10/2/09	△C	R & R For Approval	TMAC
10-19-09	△1	CORRECTED CHANNEL pc MARKS TO c	TMc
10/16/09	△0	For Fabrication - Customer Changes	MT
DATE	NO.	DESCRIPTION	BY

**A S P Services Inc**  
Selinsgrove, PA 17870  
(570) 374-5333 FAX (570) 374-5335 aspsservicesinc.com

DESCRIPTION	DATE	JOB No.
ROOF FRAME ASSEMBLY	10/02/2009	17-052-9
DRAWN BY	DATE	DRG No.
TMAC		RF4

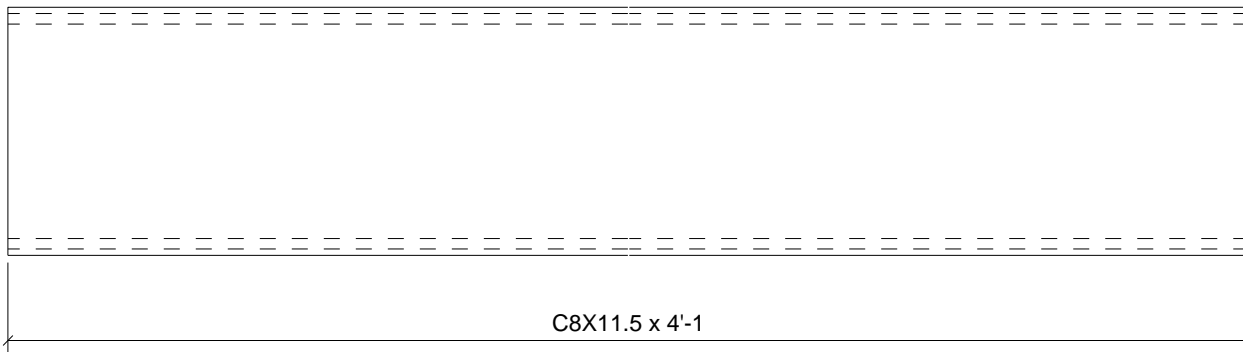

5	RF5
Qty.	In Assembly

5	RF5	C8X11.5	4'-1"	Comments	A36
Qty.	Mark	Size	Length	Comments	Grade

PROJECT NAME	LITITZ W.W.T.P.
LOCATION	WARWICK TWP.-LANCASTER CO., PA
CUSTOMER	PLEASANT MOUNT WELDING, INC.
ARCHITECT	ENTECH ENGINEERING, INC.

<b>A S P Services Inc</b>	
Selinsgrove, PA 17870	
(570) 374-5333 FAX (570) 374-5335 <a href="http://aspservicesinc.co">aspservicesinc.co</a>	
DESCRIPTION	CHANNEL
DATE	10/19/2009
JOB No.	17-052-9
DRAWN BY	TMAC
DRG No.	RF5

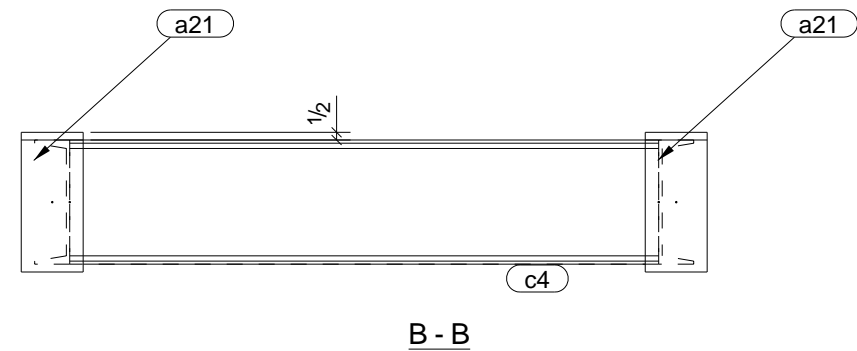
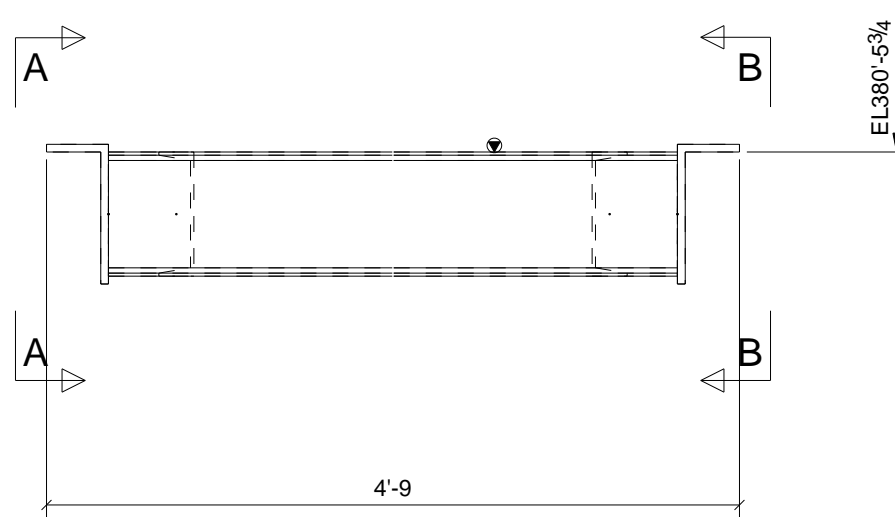
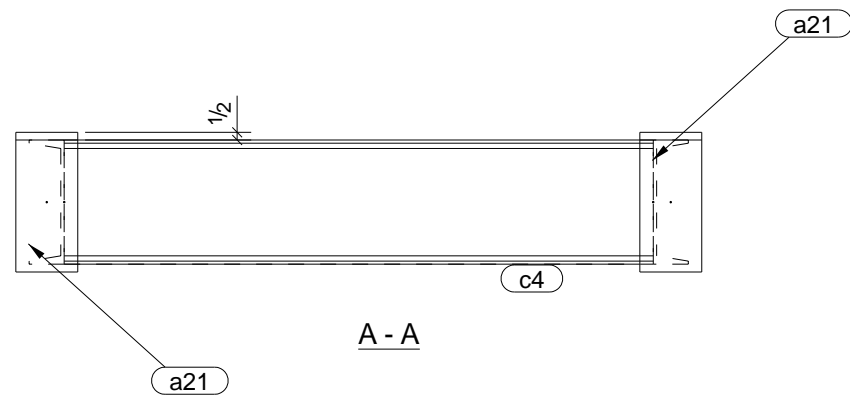
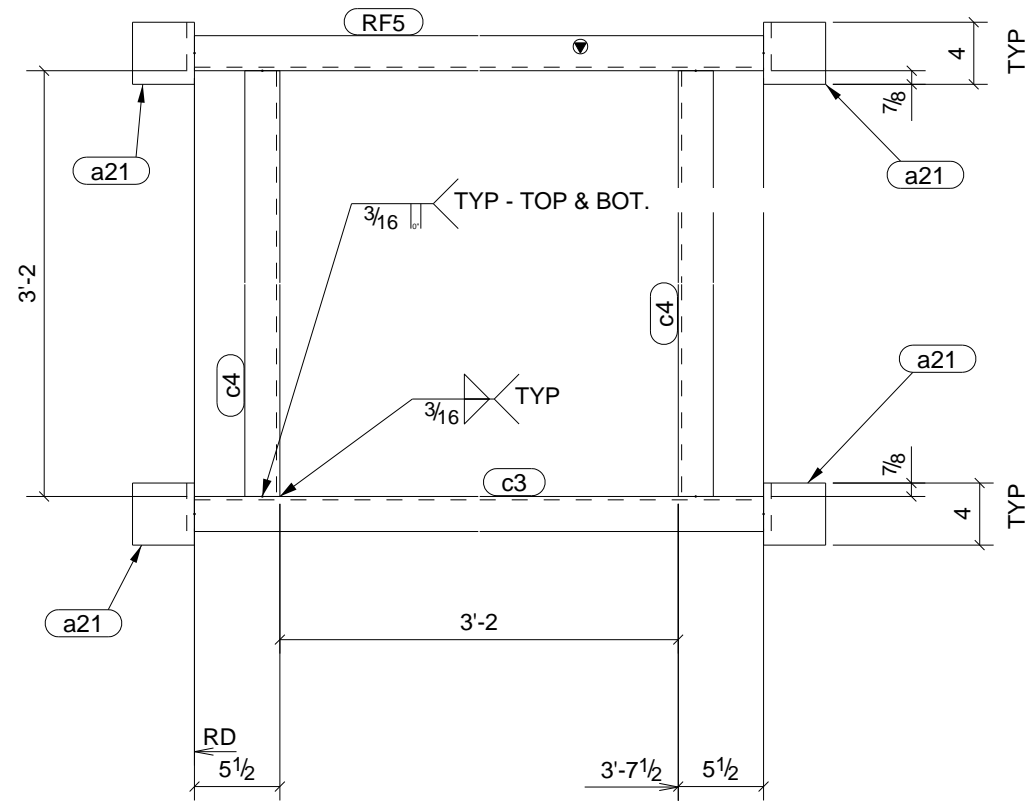

**5 - ROOF FRAMES - RF5**

**BILL OF MATERIAL**

Qty Ea.	Qty Tot	Piece Mark	Description	Length	Weight Total	Remarks	Adv Mill #	Steel Grade
	5	RF5	ROOF FRAMES					
5	5		C8X11.5	4'-1"	234	SQ-2		A36
4	20	a21	L9X4X1/2	0'-4"	142			A36
1	5	c3	C8X11.5	4'-1"	234			A36
2	10	c4	C8X11.5	3'-2"	363			A36

STEEL ASTM	A992	UNO
ELECTRODES	E70xx LH	UNO
WELDS	1/4 BUTT/FILLET	UNO
OPEN HOLES	13/16"	UNO
BOLTS	3/4"Ø A325-N-ST	UNO
PAINT	PER SPECS	UNO

PROJECT NAME	LITITZ W.W.T.P.
LOCATION	WARWICK TWP.-LANCASTER CO., PA
CONTRACTOR	PLEASANT MOUNT WELDING, INC.
ARCHITECT	ENTECH ENGINEERING, INC.

10/2/09	△C	R & R For Approval	TMAC
10-19-09	△1	CORRECTED CHANNEL pc MARKS TO c	TMc
10/16/09	△0	For Fabrication - Customer Changes	MT
DATE	NO.	DESCRIPTION	BY

<b>A S P Services Inc</b> Selinsgrove, PA 17870 (570) 374-5333 FAX (570) 374-5335 aspservicesinc.com		
DESCRIPTION	DATE	JOB No.
ROOF FRAME ASSEMBLY	10/02/2009	17-052-9
	DRAWN BY	DRG No.
	TMAC	RF5

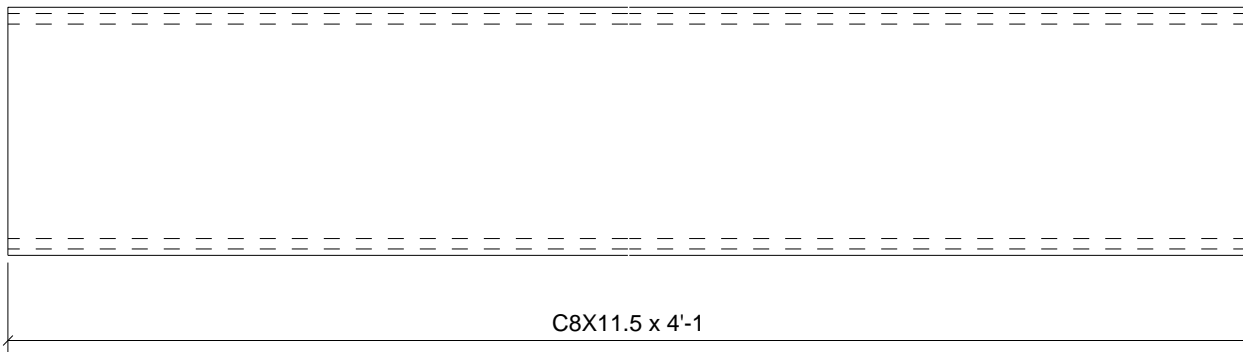

2	RF6
Qty.	In Assembly

2	RF6	C8X11.5	4'-1"	Comments	A36
Qty.	Mark	Size	Length	Comments	Grade

PROJECT NAME	LITITZ W.W.T.P.
LOCATION	WARWICK TWP.-LANCASTER CO., PA
CUSTOMER	PLEASANT MOUNT WELDING, INC.
ARCHITECT	ENTECH ENGINEERING, INC.

<b>A S P Services Inc</b>	
Selinsgrove, PA 17870	
(570) 374-5333 FAX (570) 374-5335 <a href="http://aspservicesinc.co">aspservicesinc.co</a>	
DESCRIPTION	CHANNEL
DATE	10/19/2009
JOB No.	17-052-9
DRAWN BY	TMAC
DRG No.	RF6

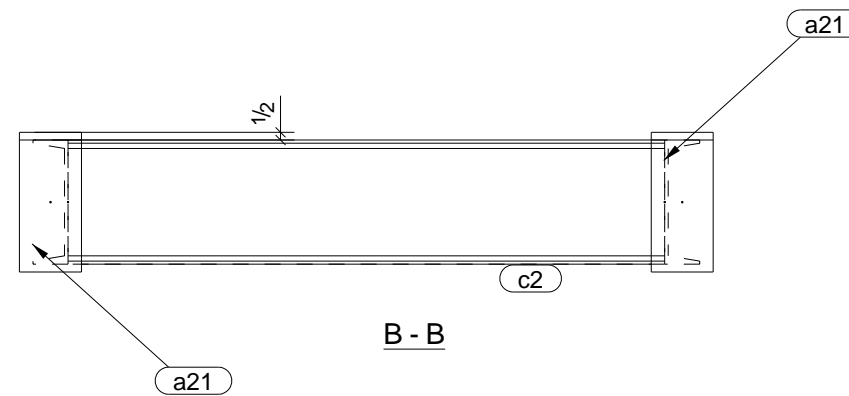
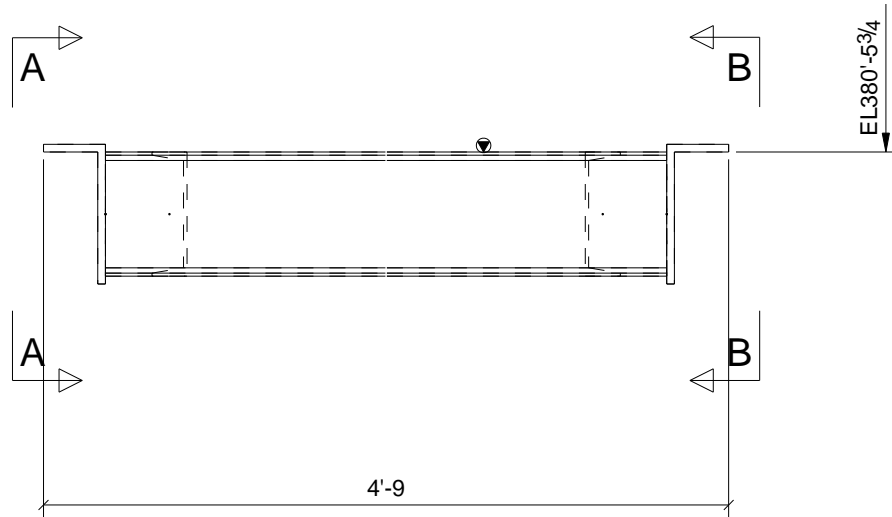
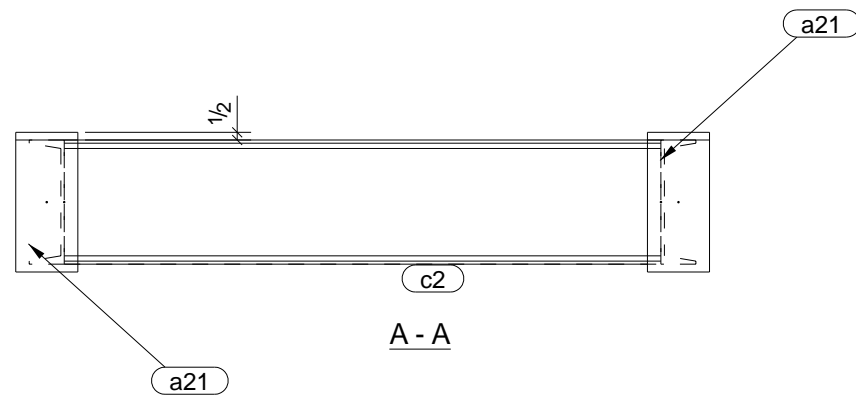
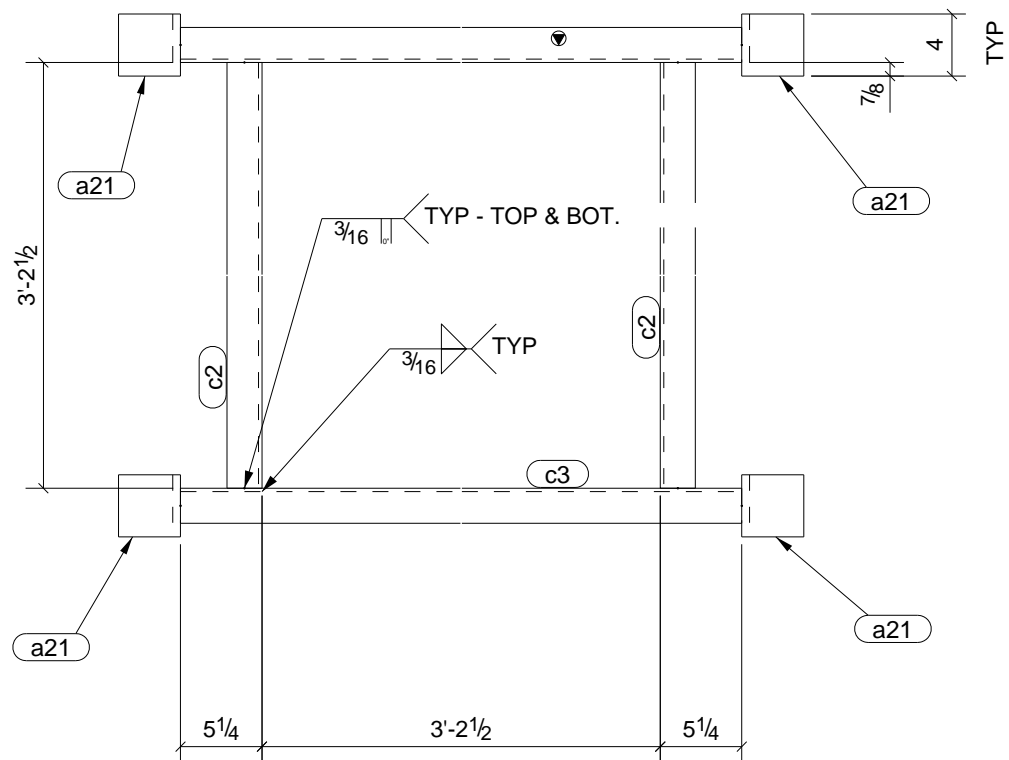

**2 - ROOF FRAMES - RF6**

**BILL OF MATERIAL**

Qty Ea.	Qty Tot	Piece Mark	Description	Length	Weight Total	Remarks	Adv Mill #	Steel Grade
	2	RF6	ROOF FRAMES					
2	2		C8X11.5	4'-1"	94	SQ-2		A36
4	8	a21	L9X4X1/2	0'-4"	57			A36
2	4	c2	C8X11.5	3'-2 1/2"	147			A36
1	2	c3	C8X11.5	4'-1"	94			A36

STEEL ASTM	A992	UNO
ELECTRODES	E70xx LH	UNO
WELDS	1/4 BUTT/FILLET	UNO
OPEN HOLES	13/16"	UNO
BOLTS	3/4"Ø A325-N-ST	UNO
PAINT	PER SPECS	UNO

PROJECT NAME	LITITZ W.W.T.P.
LOCATION	WARWICK TWP.-LANCASTER CO., PA
CONTRACTOR	PLEASANT MOUNT WELDING, INC.
ARCHITECT	ENTECH ENGINEERING, INC.

10/2/09	△ <sub>C</sub>	R & R For Approval	TMAC
10-19-09	△ <sub>1</sub>	CORRECTED CHANNEL pc MARKS TO c	TMc
10/16/09	△ <sub>0</sub>	For Fabrication - Customer Changes	MT
DATE	NO.	DESCRIPTION	BY

<b>A S P Services Inc</b> Selinsgrove, PA 17870 (570) 374-5333 FAX (570) 374-5335 aspervicesinc.com		
DESCRIPTION	DATE	JOB No.
ROOF FRAME ASSEMBLY	10/02/2009	17-052-9
	DRAWN BY	DRG No.
	TMAC	RF6

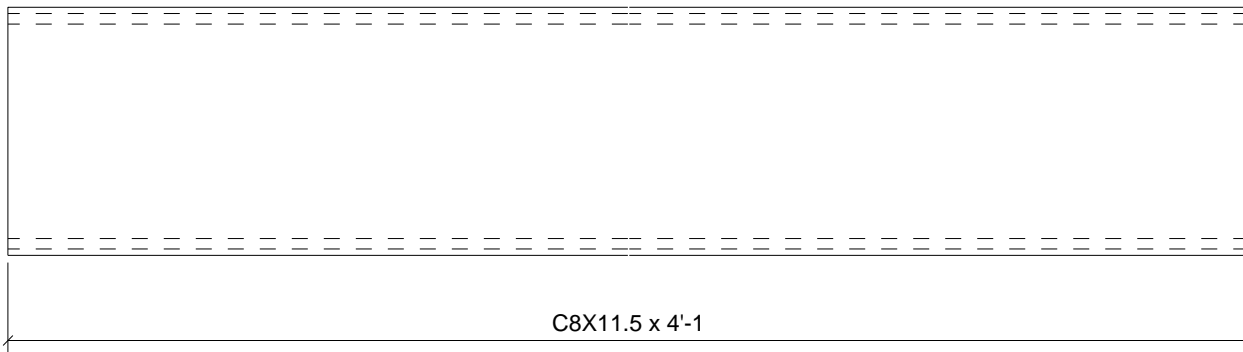

1	RF7
Qty.	In Assembly

1	RF7	C8X11.5	4'-1"		A36
Qty.	Mark	Size	Length	Comments	Grade

PROJECT NAME	LITITZ W.W.T.P.
LOCATION	WARWICK TWP.-LANCASTER CO., PA
CUSTOMER	PLEASANT MOUNT WELDING, INC.
ARCHITECT	ENTECH ENGINEERING, INC.

<b>A S P Services Inc</b> Selinsgrove, PA 17870 (570) 374-5333 FAX (570) 374-5335 asp-services-inc.co		DATE	JOB No.
		10/19/2009	17-052-9
DESCRIPTION	CHANNEL	DRAWN BY	DRG No.
		TMAC	RF7



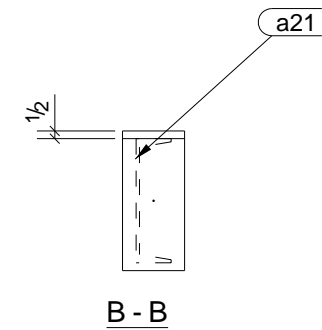
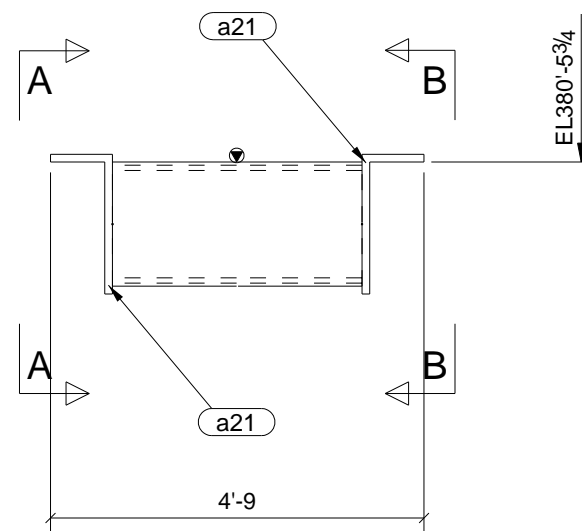
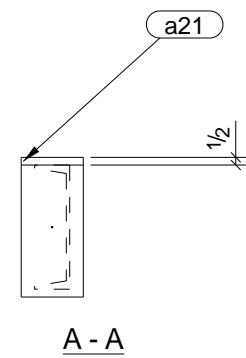
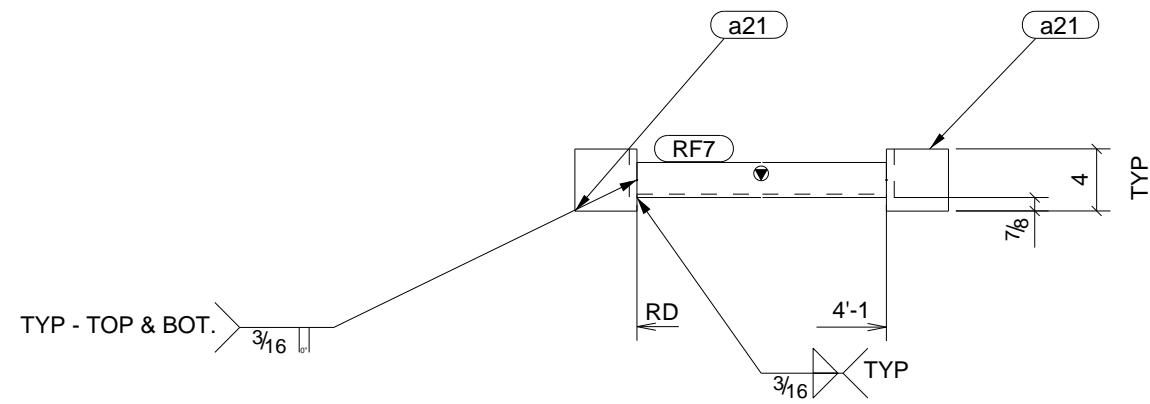

**ONE - ROOF FRAME - RF7**

**BILL OF MATERIAL**

Qty Ea.	Qty Tot	Piece Mark	Description	Length	Weight Total	Remarks	Adv Mill #	Steel Grade	STEEL ASTM	WELDS	OPEN HOLES	BOLTS	PAINT	PROJECT NAME	LOCATION	CONTRACTOR	ARCHITECT	DATE	NO.	DESCRIPTION	BY
									A992	1/4 BUTT/FILLET	13/16"	3/4"Ø A325-N-ST	PER SPECS	LITITZ W.W.T.P.	WARWICK TWP.-LANCASTER CO., PA	PLEASANT MOUNT WELDING, INC.	ENTECH ENGINEERING, INC.				
	1	RF7	ROOF FRAME																		
1	1		C8X11.5	4'-1"	47	SQ-2		A36										10/02/2009		ROOF FRAME ASSEMBLY	
2	2	a21	L9X4X1/2	0'-4"	14			A36													17-052-9
																					RF7

DATE	NO.	DESCRIPTION	BY
		<b>A S P Services Inc</b> Selinsgrove, PA 17870 (570) 374-5333 FAX (570) 374-5335 aspsservicesinc.com	
DESCRIPTION	DATE	JOB No.	
ROOF FRAME ASSEMBLY	10/02/2009	17-052-9	
	DRAWN BY	DRG No.	
	TMAC	RF7	

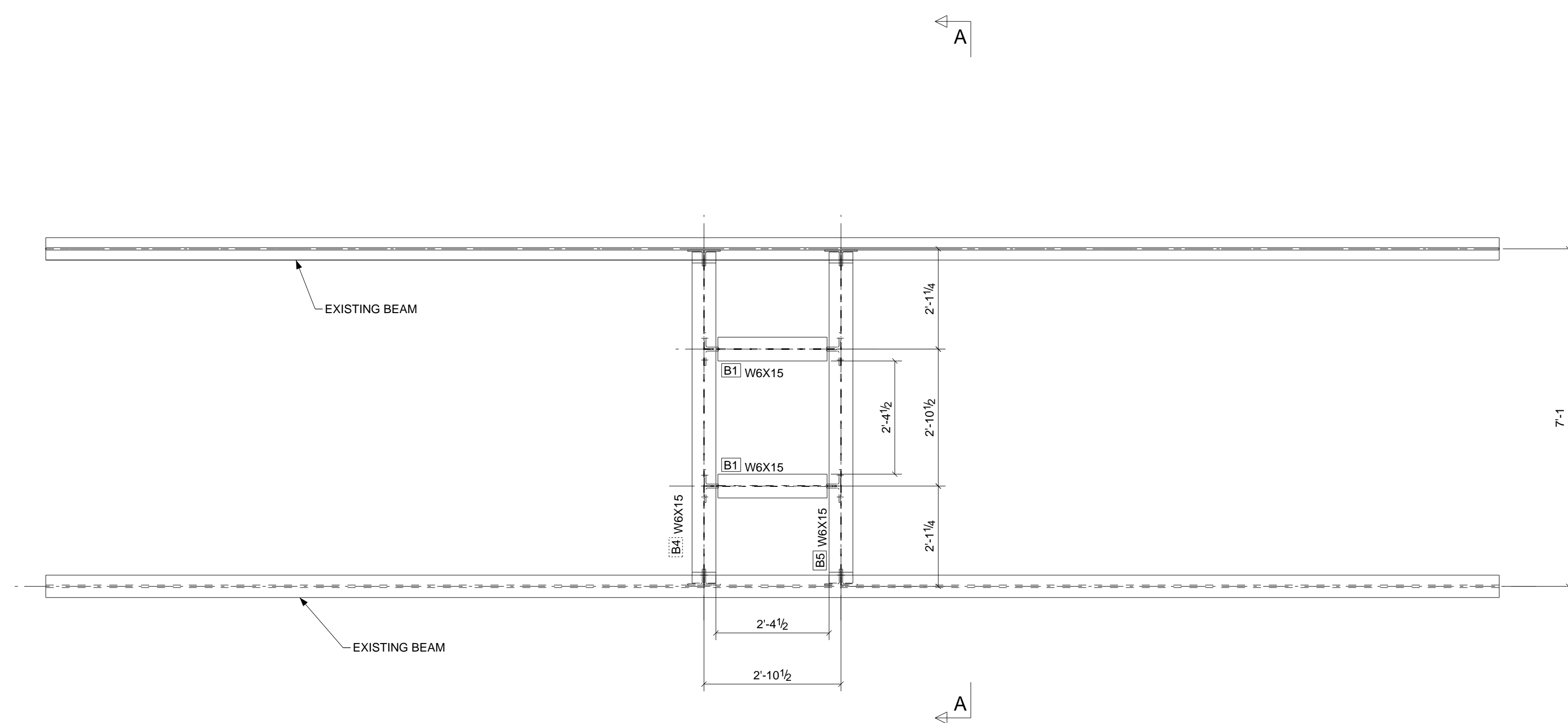

PLAN AT EL. +373'-4 (+/-)

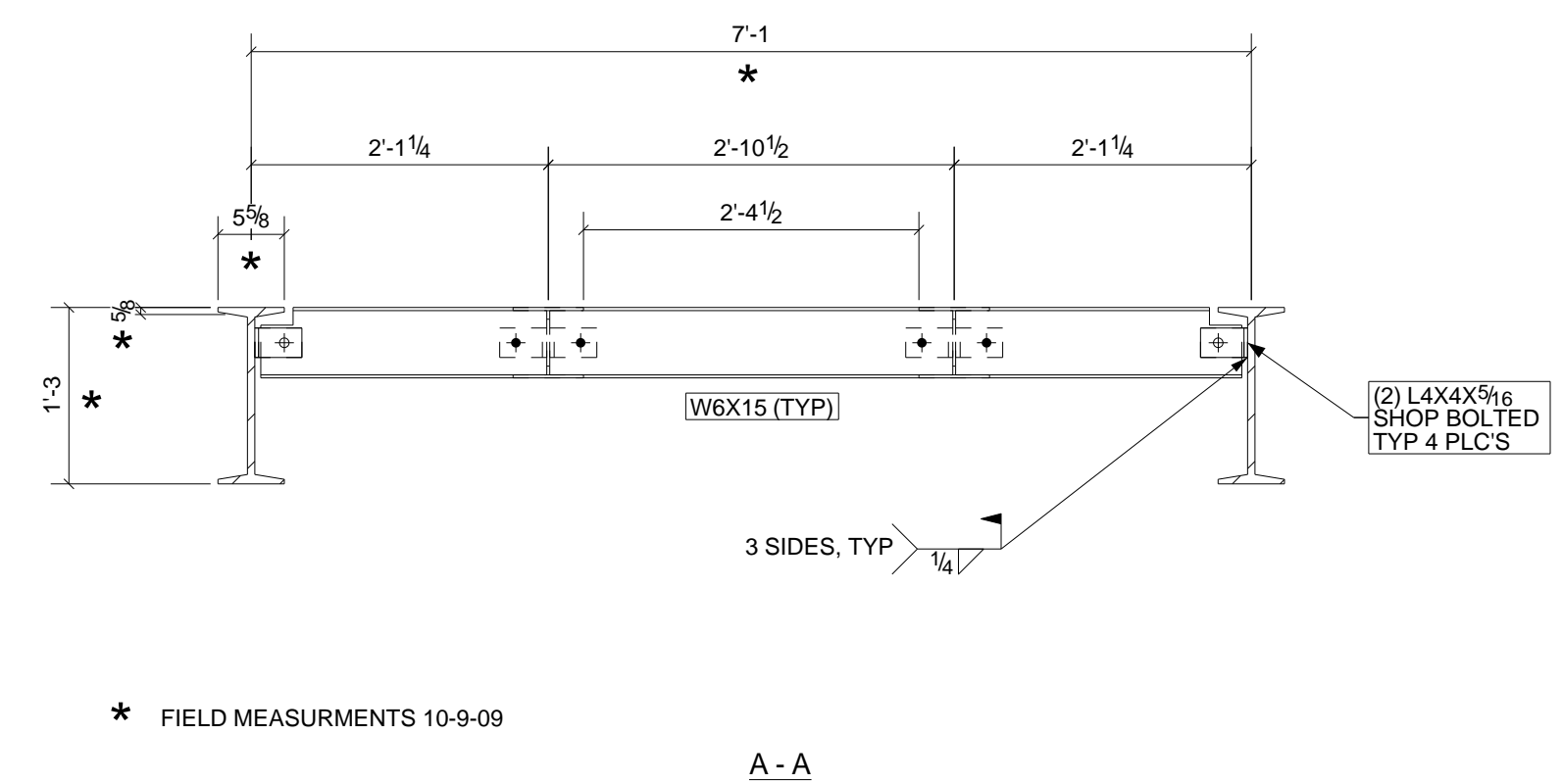

A - A

DATE	NO.	DESCRIPTION	BY	STEEL ASTM	ELECTRODES	WELDS	OPEN HOLES	BOLTS	PAINT	PROJECT NAME	LOCATION	CONTRACTOR	ARCHITECT	DESCRIPTION	DATE	JOB No.	ORG No.
5/12/09	1	For Approval	TMAC	A992	E70xx LH	1/4 BUTT/FILLET	13/16"	3/4" A325-N-ST	PER SPECS	LITITZ W.W.T.P.	WARWICK TWP.-LANCASTER CO., PA	PLEASANT MOUNT WELDING, INC.	ENTECH ENGINEERING,	AEROBIC DIGESTER TANK/BLDG	05/12/2009	17-052-9	E4-1
6/04/09	2	For Approval	TMAC														
10/15/09	3	R & R For Approval	TMAC														
10/30/09	4	For Fabrication w/ Approver Comments	MT														

**A S P Services Inc**  
 Selinsgrove, PA 17870  
 (570) 374-5333 FAX (570) 374-5335 asp-servicesinc.com

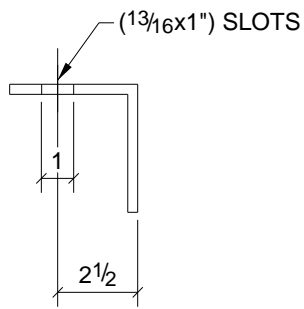

A - A

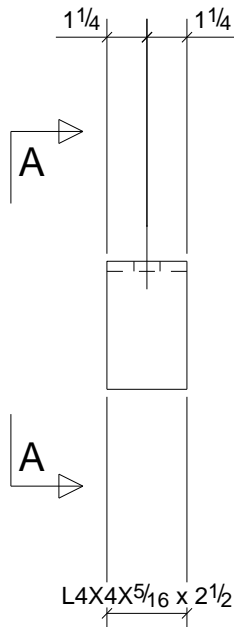

4	B4
4	B5
Qty.	In Assembly

8	a13	L4X4X5/16	0'-2 1/2"		A36
Qty.	Mark	Size	Length	Comments	Grade

PROJECT NAME <b>LITITZ W.W.T.P.</b>		<b>A S P Services Inc</b> Selinsgrove, PA 17870 (570) 374-5333 FAX (570) 374-5335 <a href="http://aspservicesinc.co">aspservicesinc.co</a>			
LOCATION <b>WARWICK TWP.-LANCASTER CO., PA</b>					
CUSTOMER <b>PLEASANT MOUNT WELDING, INC.</b>		DESCRIPTION <b>ANGLE</b>	DATE <b>06/04/2009</b>	JOB No. <b>17-052-9</b>	
ARCHITECT <b>ENTECH ENGINEERING, INC.</b>			DRAWN BY <b>TMAC</b>	DRG No. <b>a13</b>	

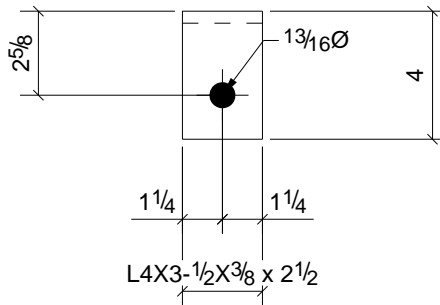

				8	B1
				Qty.	In Assembly
8	a3	L4X3-1/2X3/8	0'-2 1/2"	A36	
Qty.	Mark	Size	Length	Comments	Grade

PROJECT NAME <b>LITITZ W.W.T.P.</b>		<b>A S P Services Inc</b> Selinsgrove, PA 17870 (570) 374-5333 FAX (570) 374-5335 <a href="http://aspservicesinc.co">aspservicesinc.co</a>			
LOCATION <b>WARWICK TWP.-LANCASTER CO., PA</b>					
CUSTOMER <b>PLEASANT MOUNT WELDING, INC.</b>					
ARCHITECT <b>ENTECH ENGINEERING, INC.</b>					
DESCRIPTION <b>ANGLE</b>		DATE <b>10/14/2009</b>	JOB No. <b>17-052-9</b>		
		DRAWN BY <b>TMAC</b>	DRG No. <b>a3</b>		

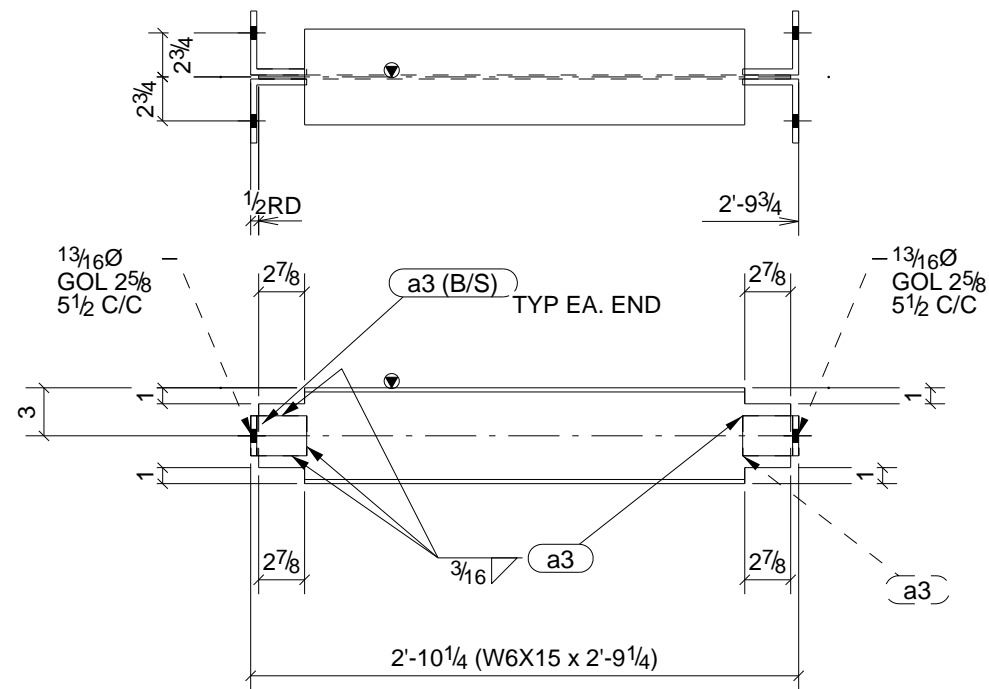

**2 - BEAMS - B1**

10/15/09		R & R For Approval	TMAC
10/30/09		For Fabrication w/ Approver Comments	MT
DATE	NO.	DESCRIPTION	BY

BILL OF MATERIAL								STEEL ASTM	A992	UNO	PROJECT NAME	LITITZ W.W.T.P.				
Qty Ea.	Qty Tot	Piece Mark	Description	Length	Weight Total	Remarks	Adv Mill #	Steel Grade	ELECTRODES	E70xx LH	UNO	LOCATION	WARWICK TWP.-LANCASTER CO., PA			
	2	B1	BEAMS						WELDS	1/4 BUTT/FILLET	UNO	CONTRACTOR	PLEASANT MOUNT WELDING, INC.			
2	2		W6X15	2'-9 1/4"	84	SQ-2		A992	OPEN HOLES	13/16"	UNO	ARCHITECT	ENTECH ENGINEERING, INC.			
4	8	a3	L4X3-1/2X3/8	0'-2 1/2"	15			A36	BOLTS	3/4"Ø A325-N-ST	UNO	DESCRIPTION		DATE	JOB No.	
										PAINT	PER SPECS	UNO	BEAM		10/15/2009	17-052-9
														DRAWN BY	DRG No.	
														TMAC	B1	

**A S P Services Inc**  
 Selinsgrove, PA 17870  
 (570) 374-5333 FAX (570) 374-5335 asp-servicesinc.com

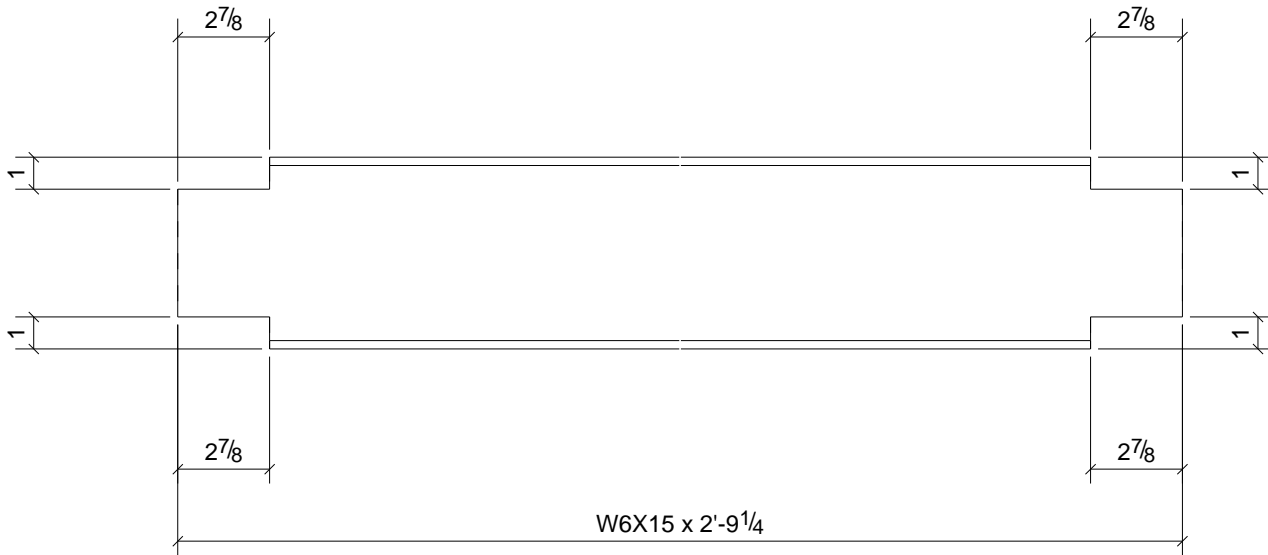

					2	B1
					Qty.	In Assembly
2	B1	W6X15	2'-9 1/4"			A992
Qty.	Mark	Size	Length	Comments		Grade

PROJECT NAME <b>LITITZ W.W.T.P.</b>	<b>A S P Services Inc</b> Selinsgrove, PA 17870 (570) 374-5333 FAX (570) 374-5335 <a href="http://aspservicesinc.co">aspservicesinc.co</a>		
LOCATION <b>WARWICK TWP.-LANCASTER CO., PA</b>			
CUSTOMER <b>PLEASANT MOUNT WELDING, INC.</b>	DESCRIPTION <b>BEAM</b>	DATE <b>10/14/2009</b>	JOB No. <b>17-052-9</b>
ARCHITECT <b>ENTECH ENGINEERING, INC.</b>		DRAWN BY <b>TMAC</b>	DRG No. <b>B1</b>

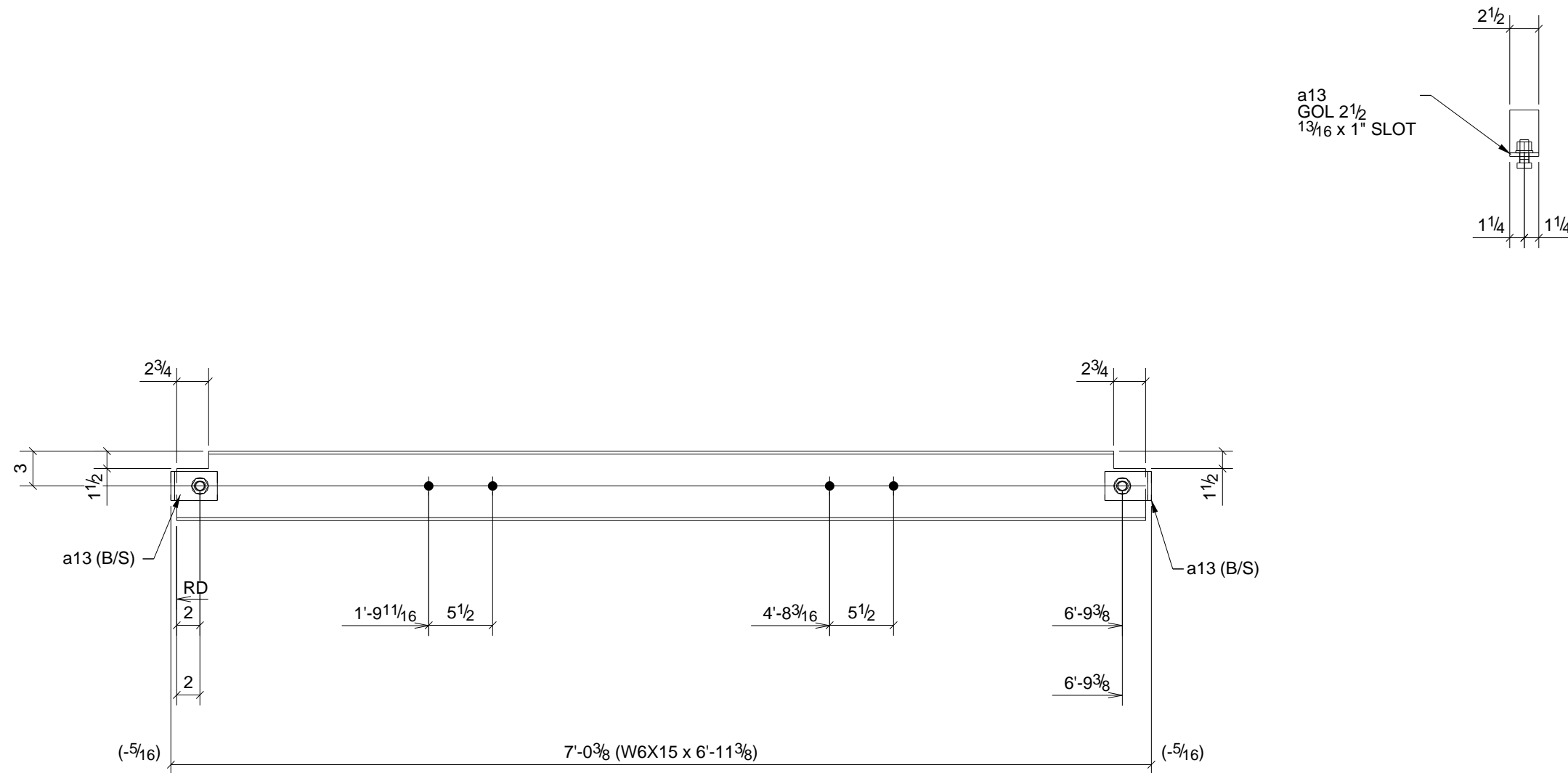

**ONE - BEAM - B4**

**BILL OF MATERIAL**

Qty Ea.	Qty Tot	Piece Mark	Description	Length	Weight Total	Remarks	Adv Mill #	Steel Grade
	1	B4	BEAM					
1	1		W6X15	6'-11 3/8"	105	SQ-2		A992
4	4	a13	L4X4X5/16	0'-2 1/2"	7			A36
2	2		3/4"Ø A325N BOLT	0'-2"	1			

STEEL ASTM	A992	UNO	PROJECT NAME	LITITZ W.W.T.P.
ELECTRODES	E70xx LH	UNO	LOCATION	WARWICK TWP.-LANCASTER CO., PA
WELDS	1/4 BUTT/FILLET	UNO	CONTRACTOR	PLEASANT MOUNT WELDING, INC.
OPEN HOLES	13/16"	UNO	ARCHITECT	ENTECH ENGINEERING, INC.
BOLTS	3/4"Ø A325-N-ST	UNO		
PAINT	PER SPECS	UNO		

10/15/09		R & R For Approval	TMAC
10/30/09		For Fabrication w/ Approver Comments	MT
DATE	NO.	DESCRIPTION	BY
		<b>A S P Services Inc</b> Selinsgrove, PA 17870 (570) 374-5333 FAX (570) 374-5335 aspervicesinc.com	
DESCRIPTION	DATE	JOB No.	
BEAM	10/14/2009	17-052-9	
	DRAWN BY	DRG No.	
	TMAC	B4	

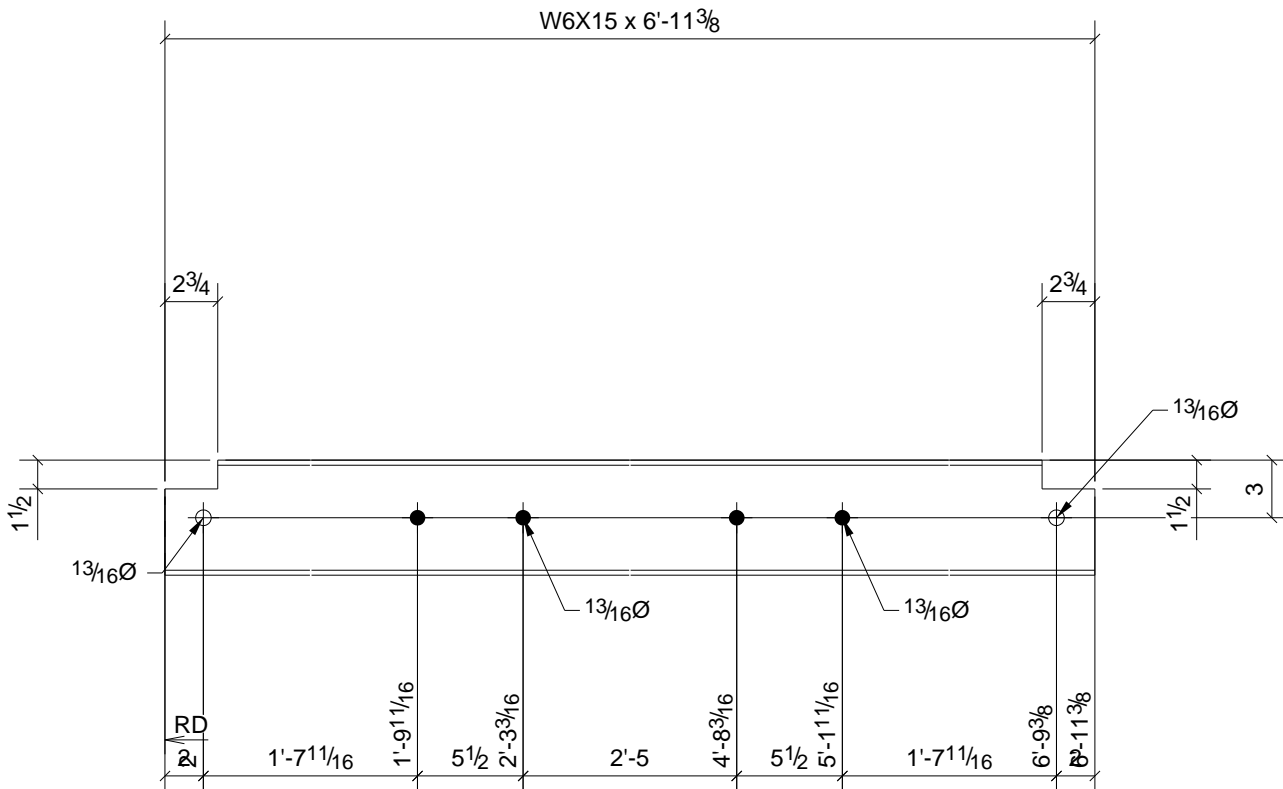

1	B4
Qty.	In Assembly

1	B4	W6X15	6'-11 3/8"		A992
Qty.	Mark	Size	Length	Comments	Grade

PROJECT NAME <b>LITITZ W.W.T.P.</b>		<b>A S P Services Inc</b> Selinsgrove, PA 17870 (570) 374-5333 FAX (570) 374-5335 <a href="http://aspservicesinc.co">aspservicesinc.co</a>			
LOCATION <b>WARWICK TWP.-LANCASTER CO., PA</b>					
CUSTOMER <b>PLEASANT MOUNT WELDING, INC.</b>		DESCRIPTION <b>BEAM</b>	DATE <b>10/14/2009</b>	JOB No. <b>17-052-9</b>	
ARCHITECT <b>ENTECH ENGINEERING, INC.</b>			DRAWN BY <b>TMAC</b>	DRG No. <b>B4</b>	



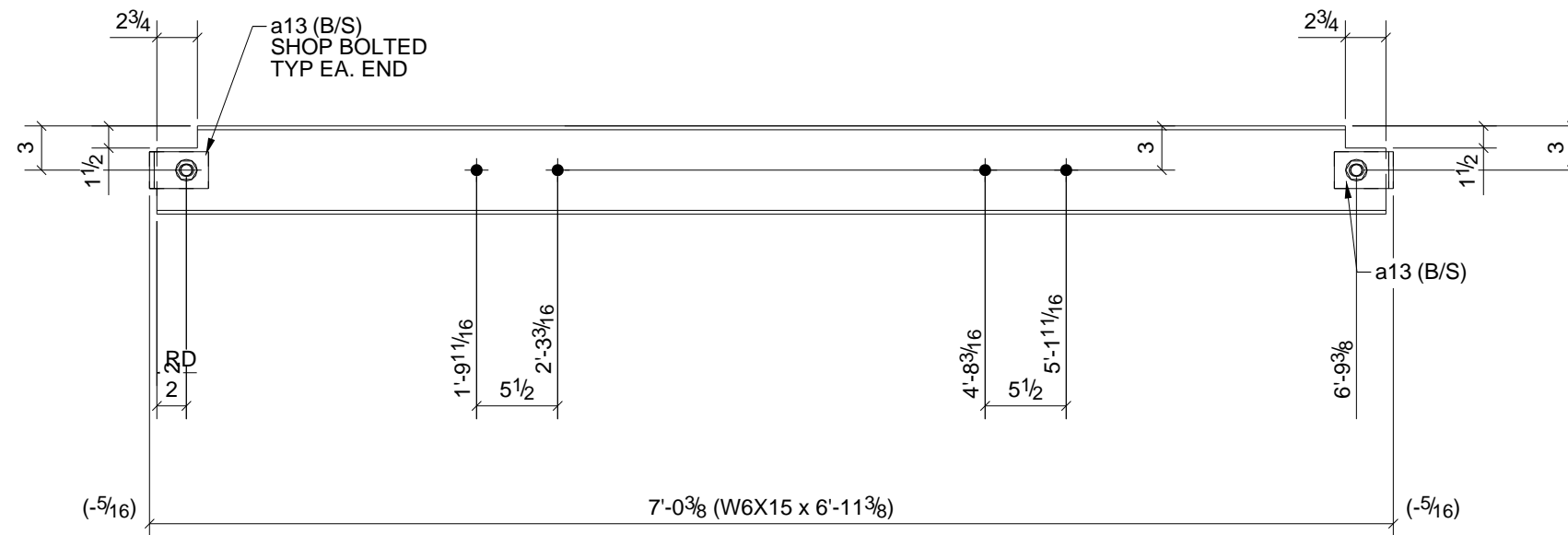

**ONE - BEAM - B5**

**BILL OF MATERIAL**

Qty Ea.	Qty Tot	Piece Mark	Description	Length	Weight Total	Remarks	Adv Mill #	Steel Grade
	1	B5	BEAM					
1	1		W6X15	6'-11 3/8"	105	SQ-2		A992
4	4	a13	L4X4X5/16	0'-2 1/2"	7			A36
2	2		3/4"Ø A325N BOLT	0'-2"	1			

STEEL ASTM	A992	UNO	PROJECT NAME	LITITZ W.W.T.P.
ELECTRODES	E70xx LH	UNO	LOCATION	WARWICK TWP.-LANCASTER CO., PA
WELDS	1/4 BUTT/FILLET	UNO	CONTRACTOR	PLEASANT MOUNT WELDING, INC.
OPEN HOLES	13/16"	UNO	ARCHITECT	ENTECH ENGINEERING, INC.
BOLTS	3/4"Ø A325-N-ST	UNO		
PAINT	PER SPECS	UNO		

10/15/09		R & R For Approval	TMAC
10/30/09		For Fabrication w/ Approver Comments	MT
DATE	NO.	DESCRIPTION	BY
		<b>A S P Services Inc</b> Selinsgrove, PA 17870 (570) 374-5333 FAX (570) 374-5335 asp-servicesinc.com	
DESCRIPTION	DATE	JOB No.	
BEAM	10/14/2009	17-052-9	
	DRAWN BY	DRG No.	
	TMAC	B5	

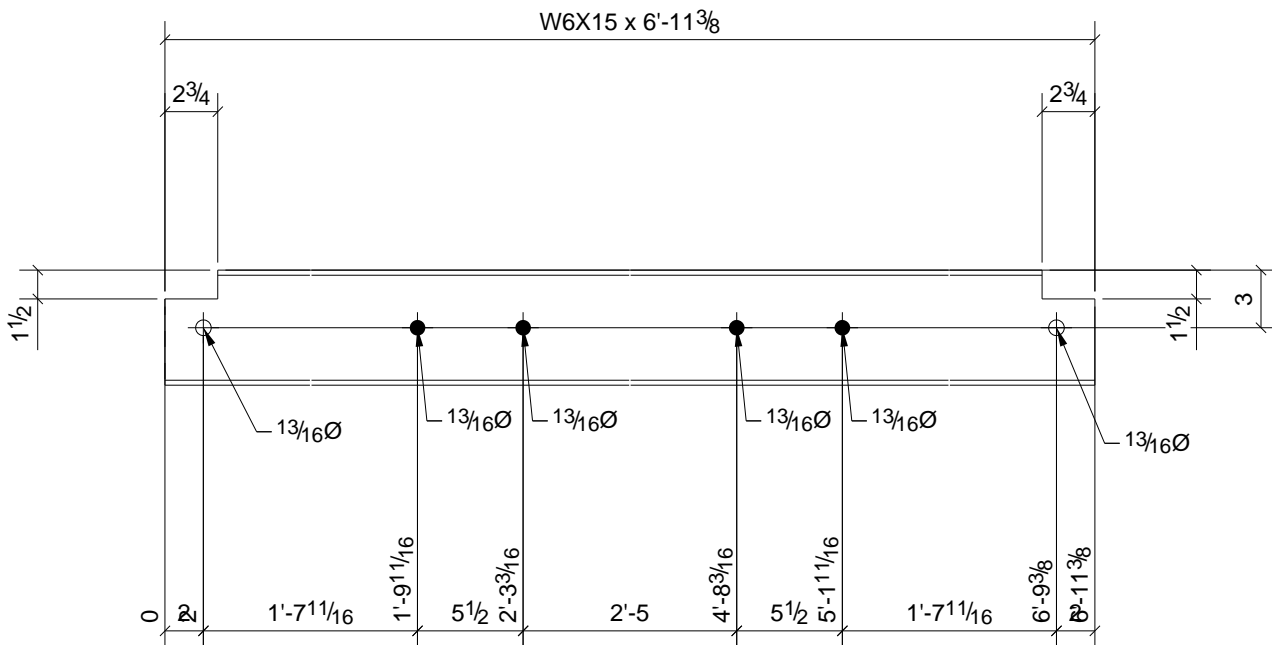

1	B5
Qty.	In Assembly

1	B5	W6X15	6'-11 3/8"	A992
Qty.	Mark	Size	Length	Comments
				Grade

PROJECT NAME <b>LITITZ W.W.T.P.</b>	<b>A S P Services Inc</b> Selinsgrove, PA 17870 (570) 374-5333 FAX (570) 374-5335 <a href="http://aspservicesinc.co">aspservicesinc.co</a>		
LOCATION <b>WARWICK TWP.-LANCASTER CO., PA</b>			
CUSTOMER <b>PLEASANT MOUNT WELDING, INC.</b>			
ARCHITECT <b>ENTECH ENGINEERING, INC.</b>			
DESCRIPTION <b>BEAM</b>	DATE <b>11/03/2009</b>	JOB No. <b>17-052-9</b>	
	DRAWN BY <b>TMAC</b>	DRG No. <b>B5</b>	

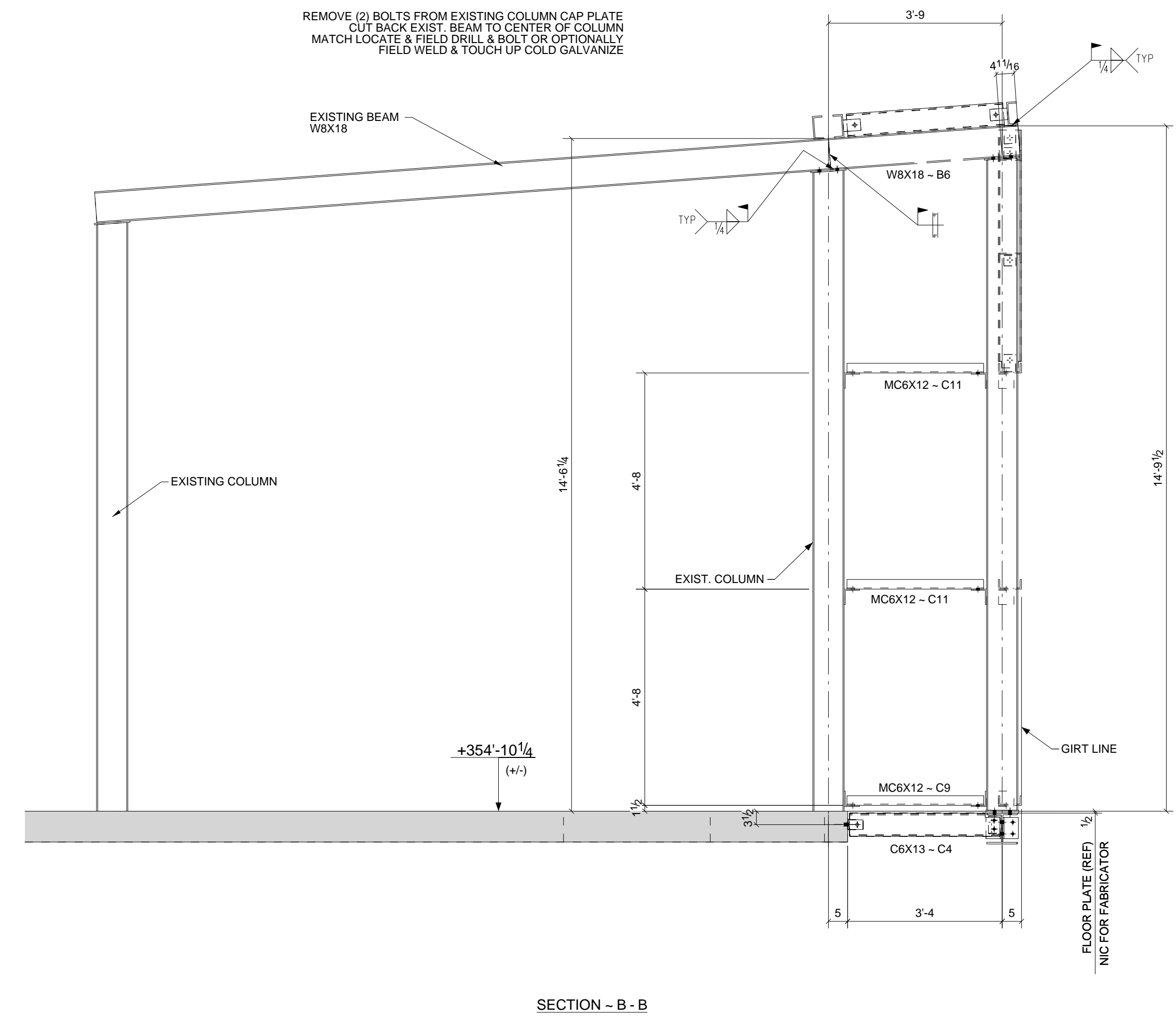
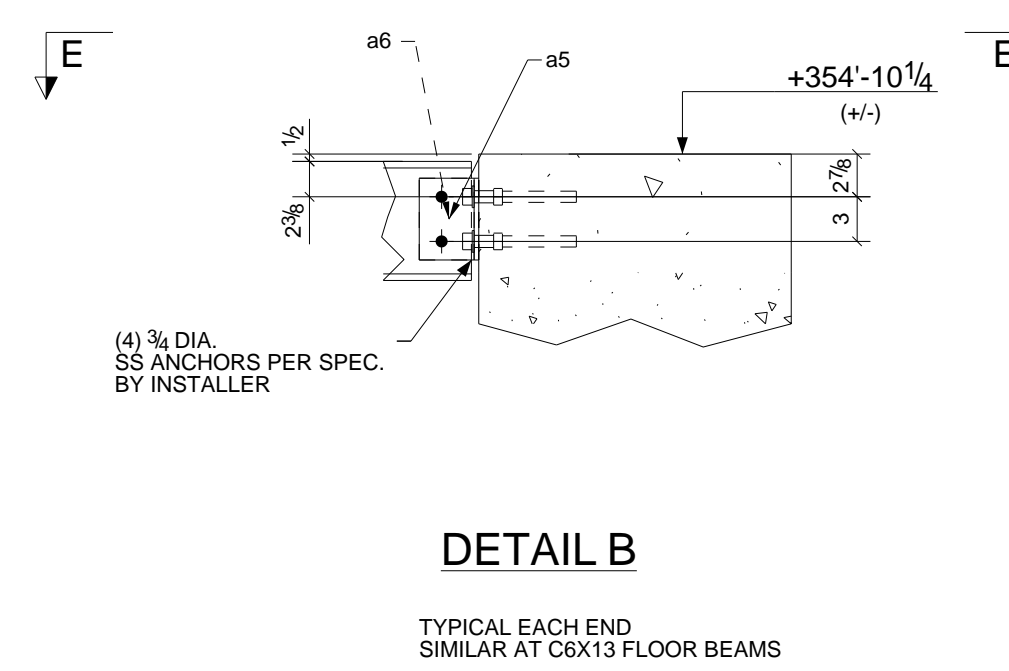
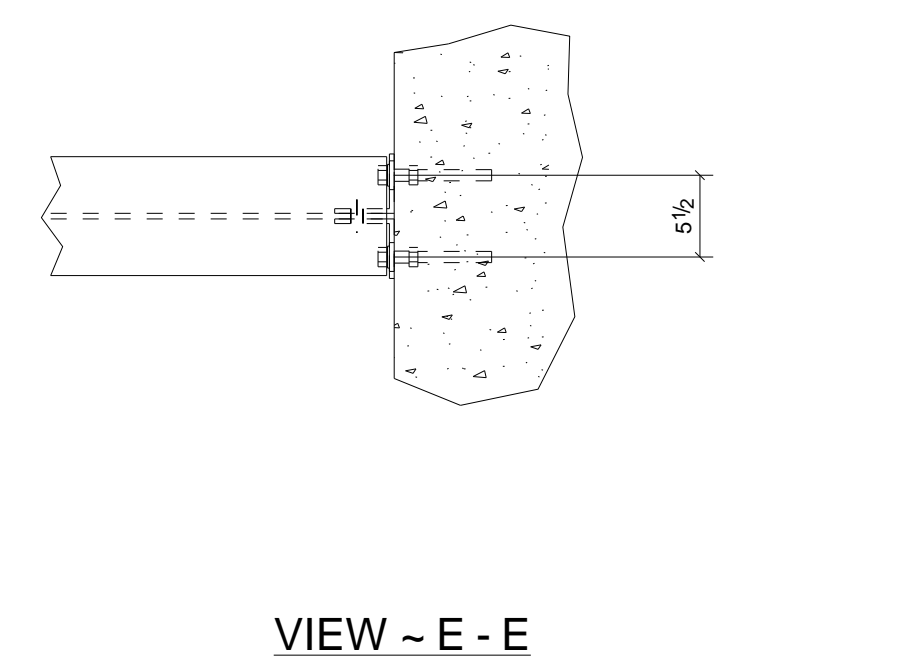
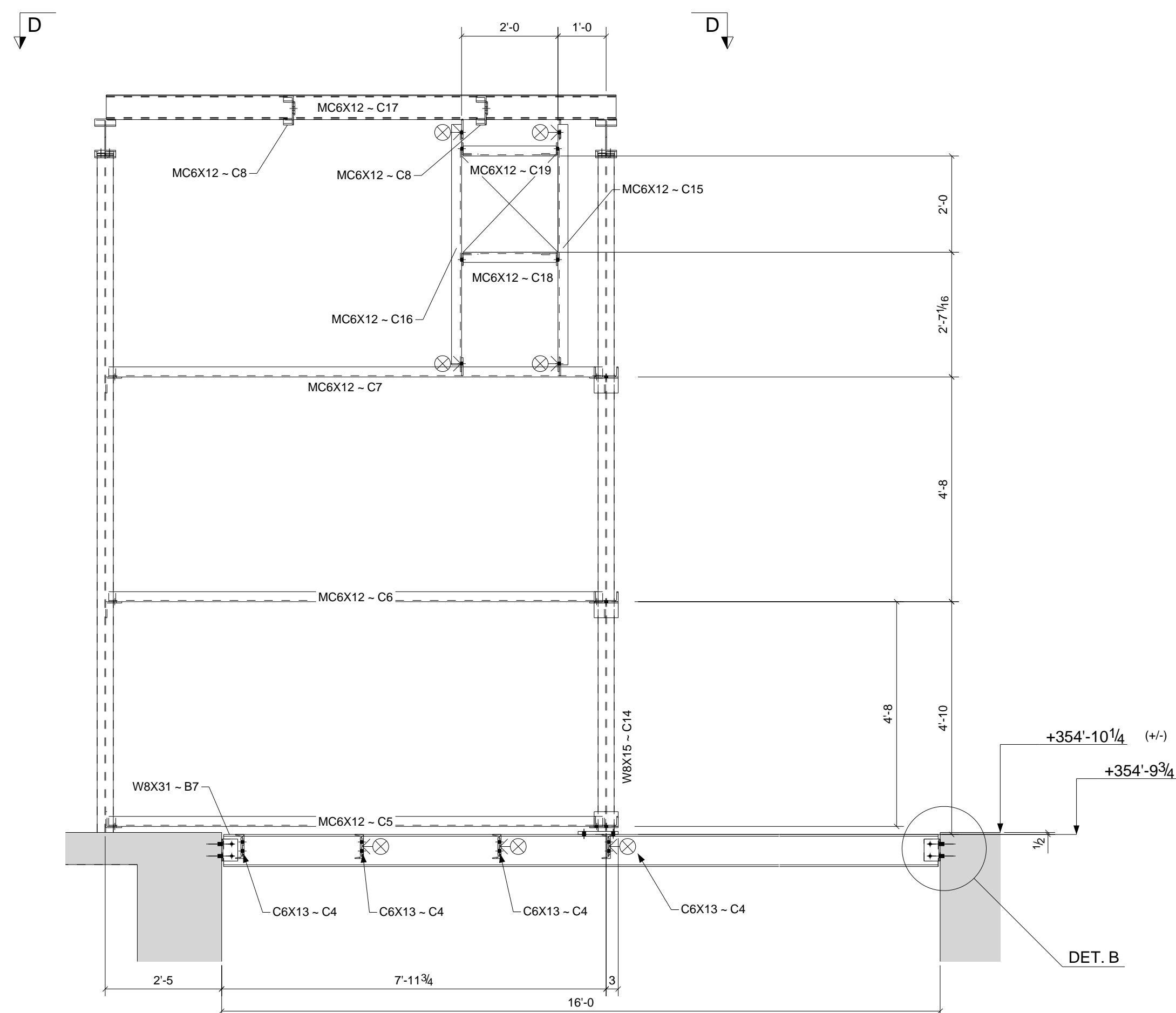
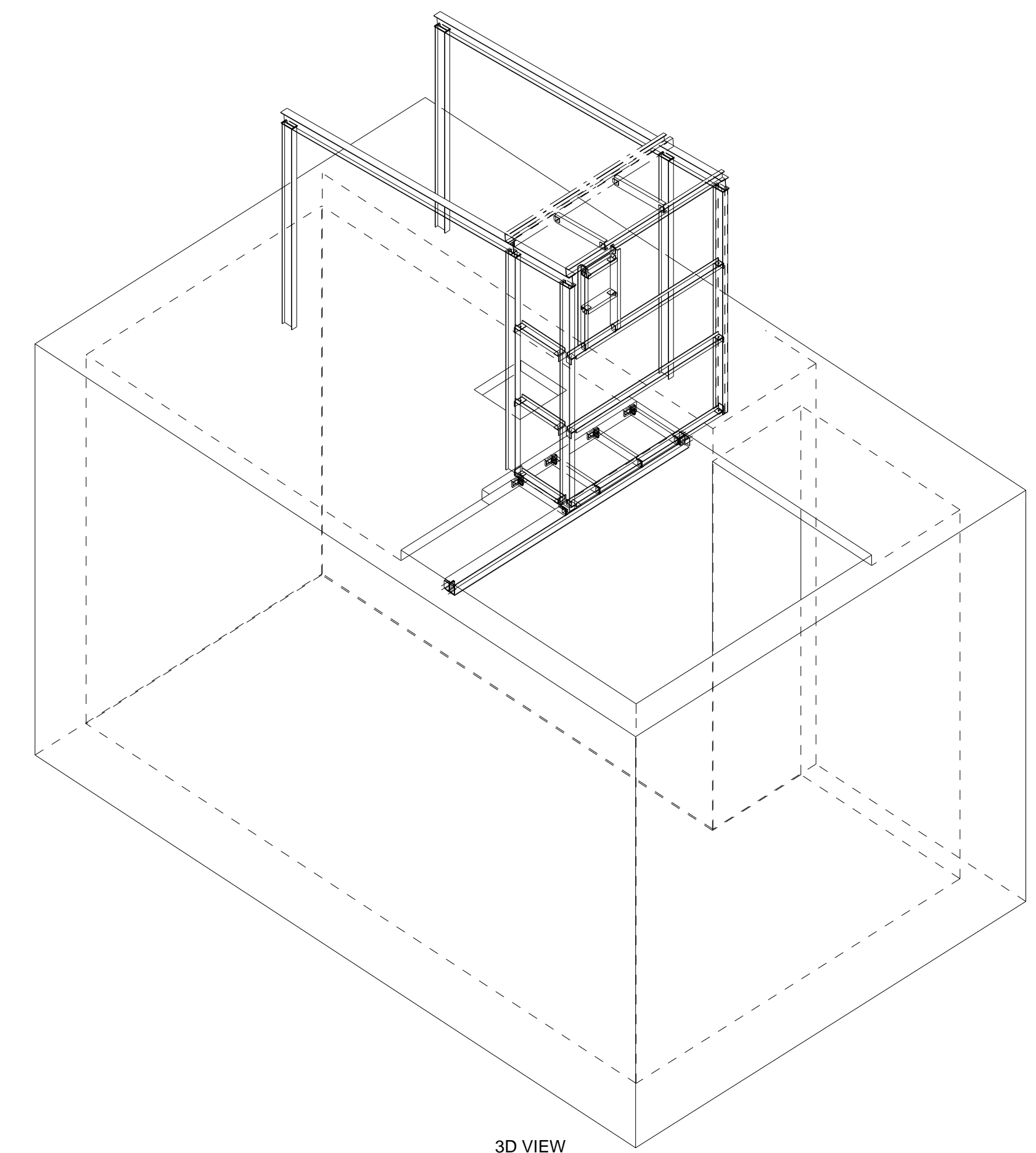
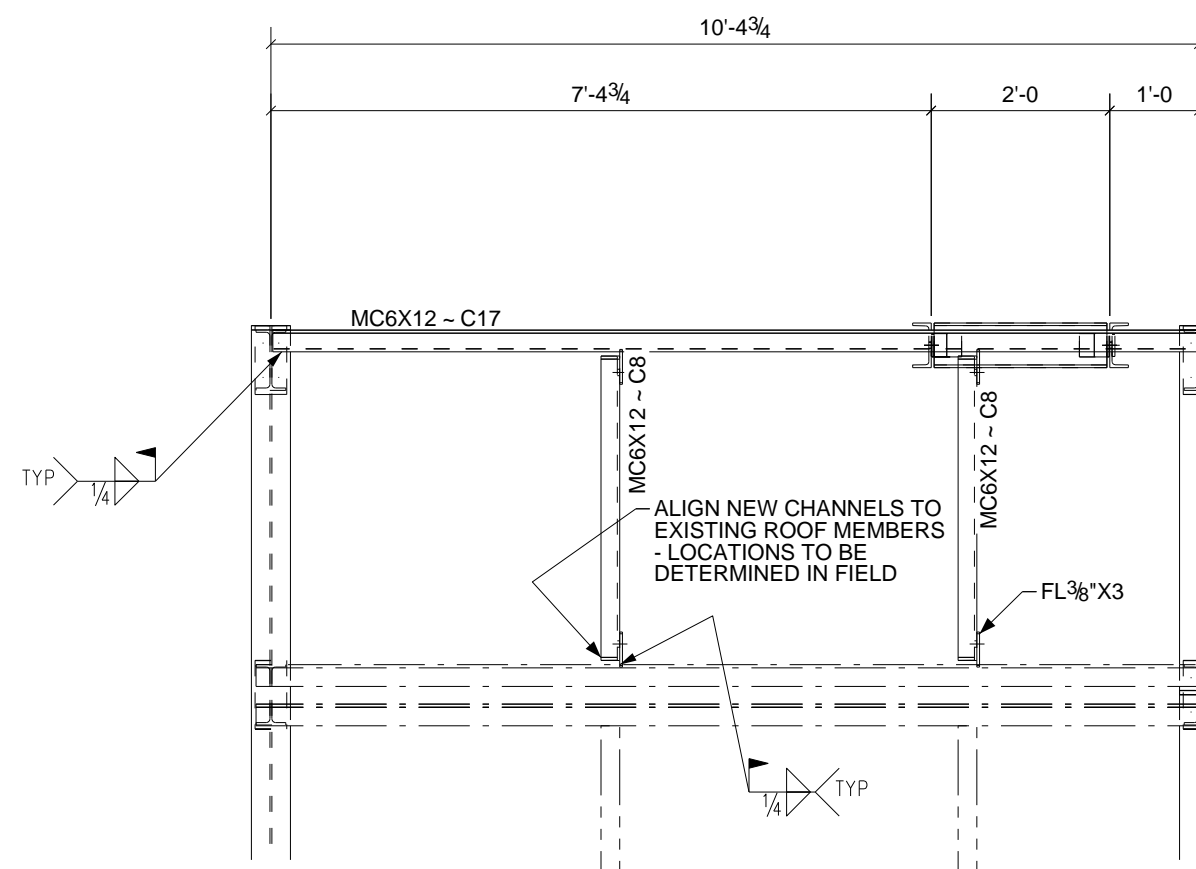
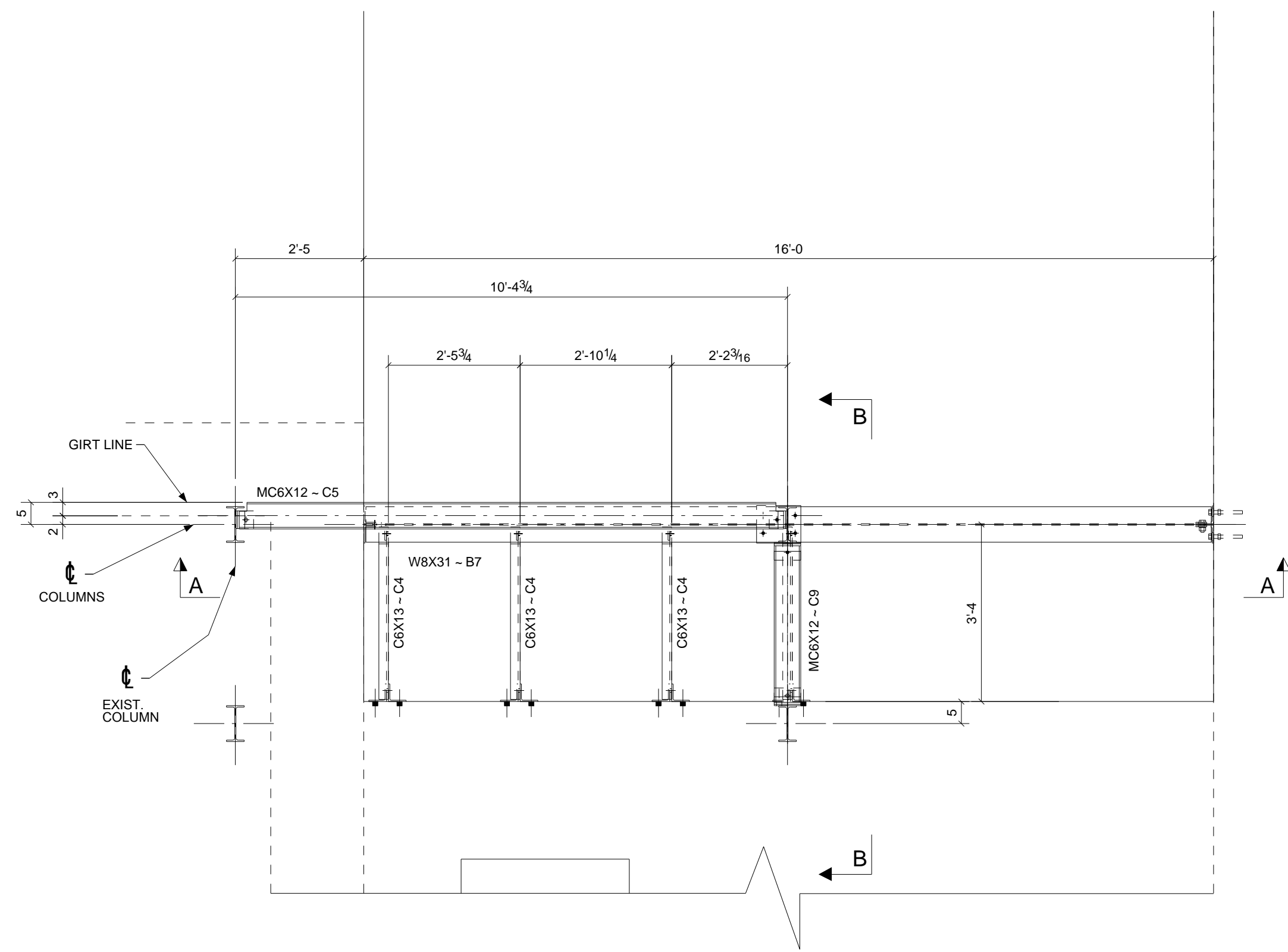

DATE	NO.	DESCRIPTION	BY	REVISION
5/12/09	1	For Approval	TMAC	OPEN HOLES 13/16"
6/04/09	2	For Approval	TMAC	BOLTS 3/4"x10" A325-N-ST
10/22/09	3	For Approval	TMAC	PAINT PER SPECS
10/30/09	4	For Fabrication w/ Approver Comments	MT	

PROJECT NAME	LOCATION	CONTRACTOR	ARCHITECT
LITITZ W.W.T.P.	WARWICK TWP.-LANCASTER CO., PA	PLEASANT MOUNT WELDING, INC.	ENTECH ENGINEERING,

DESCRIPTION	DATE	JOB NO.	DRG NO.
HEADWORKS INFLUENT SCREEN-STRUCTURAL MOQS	05/11/2009	17-052-9	E-1-1

STEEL ASTM A992  
ELECTRODES E70xx LH  
WELDS 1/4 BUTT/FILLET  
OPEN HOLES 13/16"  
BOLTS 3/4"x10" A325-N-ST  
PAINT PER SPECS

A S P Services Inc  
Selinsgrove, PA 17870  
(570) 374-5333 FAX (570) 374-5335 aspsservicesinc.com

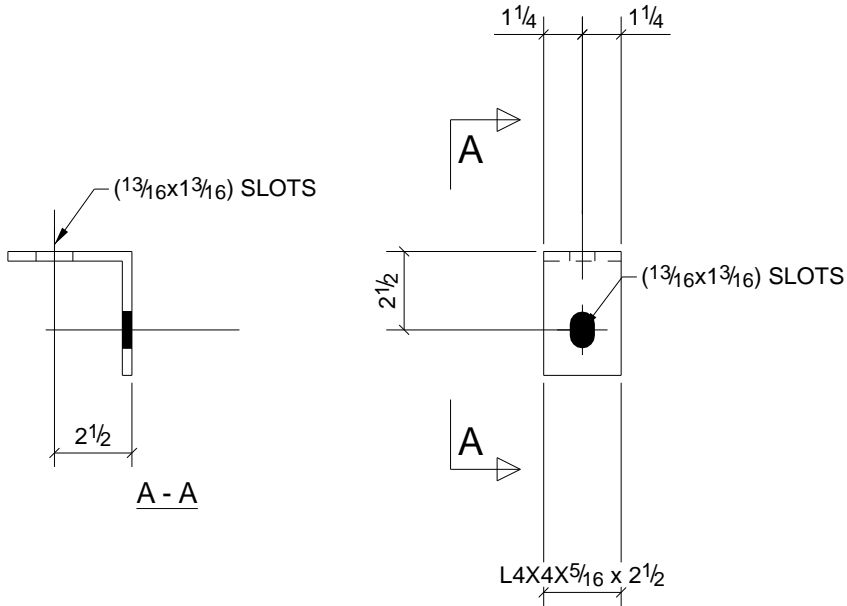

4	C4
Qty.	In Assembly

4	a10	L4X4X5/16	0'-2 1/2"		A36
Qty.	Mark	Size	Length	Comments	Grade

PROJECT NAME	LITITZ W.W.T.P.
LOCATION	WARWICK TWP.-LANCASTER CO., PA
CUSTOMER	PLEASANT MOUNT WELDING, INC.
ARCHITECT	ENTECH ENGINEERING, INC.

<b>A S P Services Inc</b>		
Selinsgrove, PA 17870		
(570) 374-5333 FAX (570) 374-5335 <a href="http://aspservicesinc.co">aspservicesinc.co</a>		
DESCRIPTION	DATE	JOB No.
	11/03/2009	17-052-9
ANGLE	DRAWN BY	DRG No.
	TMAC	a10

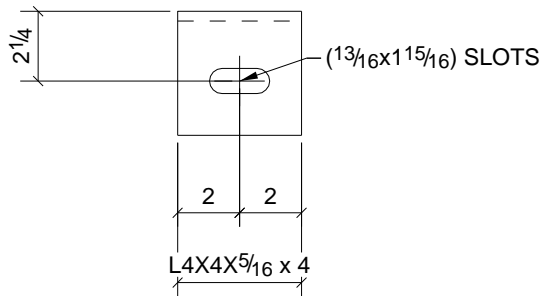

1	C5
1	C6
1	C7
Qty.	In Assembly

3	a14	L4X4X5/16	0'-4"		A36
Qty.	Mark	Size	Length	Comments	Grade

PROJECT NAME LITITZ W.W.T.P.		<b>A S P Services Inc</b> Selinsgrove, PA 17870 (570) 374-5333 FAX (570) 374-5335 asp-servicesinc.co			
LOCATION WARWICK TWP.-LANCASTER CO., PA					
CUSTOMER PLEASANT MOUNT WELDING, INC.		DESCRIPTION ANGLE	DATE 11/03/2009	JOB No. 17-052-9	
ARCHITECT ENTECH ENGINEERING, INC.			DRAWN BY	DRG No. a14	

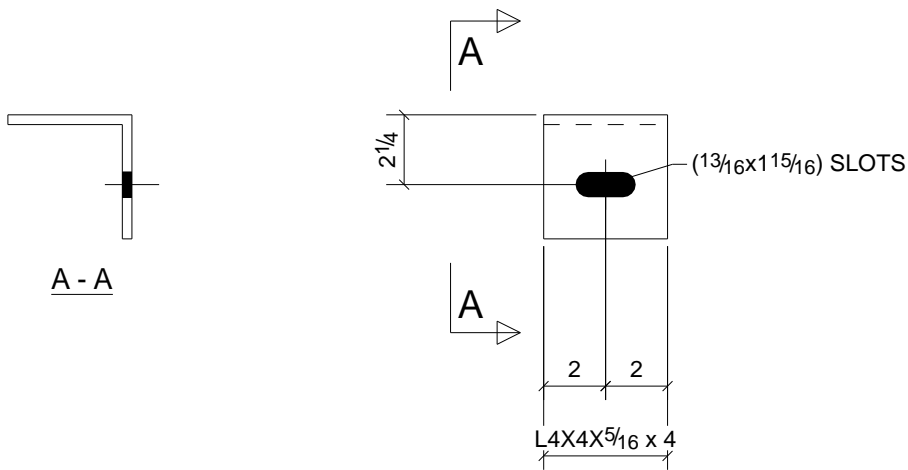

2	C14
Qty.	In Assembly

2	a15	L4X4X5/16	0'-4"		A36
Qty.	Mark	Size	Length	Comments	Grade

PROJECT NAME	LITITZ W.W.T.P.
LOCATION	WARWICK TWP.-LANCASTER CO., PA
CUSTOMER	PLEASANT MOUNT WELDING, INC.
ARCHITECT	ENTECH ENGINEERING, INC.

<b>A S P Services Inc</b>		
Selinsgrove, PA 17870		
(570) 374-5333 FAX (570) 374-5335 <a href="http://aspservicesinc.co">aspservicesinc.co</a>		
DESCRIPTION	DATE	JOB No.
	11/03/2009	17-052-9
ANGLE	DRAWN BY	DRG No.
	TMAC	a15

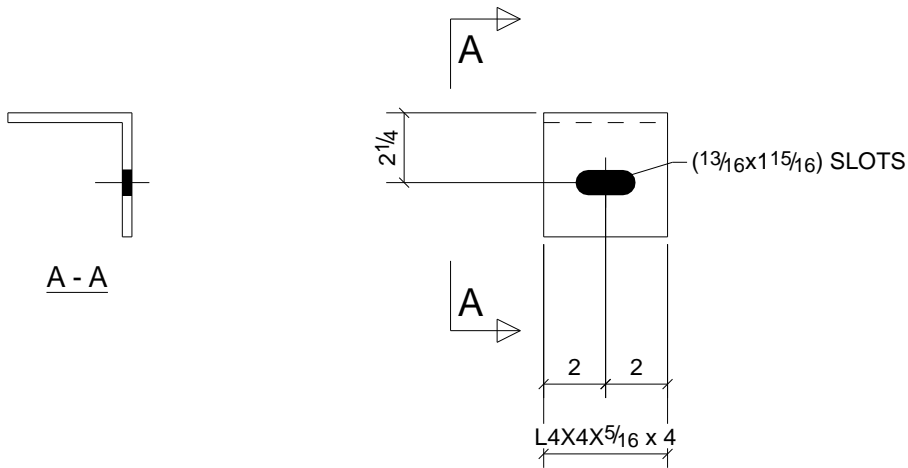

1	C14
Qty.	In Assembly

1	a16	L4X4X5/16	0'-4"		A36
Qty.	Mark	Size	Length	Comments	Grade

PROJECT NAME	LITITZ W.W.T.P.
LOCATION	WARWICK TWP.-LANCASTER CO., PA
CUSTOMER	PLEASANT MOUNT WELDING, INC.
ARCHITECT	ENTECH ENGINEERING, INC.

<b>A S P Services Inc</b>		
Selinsgrove, PA 17870		
(570) 374-5333 FAX (570) 374-5335 <a href="http://aspservicesinc.co">aspservicesinc.co</a>		
DESCRIPTION	DATE	JOB No.
	11/03/2009	17-052-9
ANGLE	DRAWN BY	DRG No.
	TMAC	a16

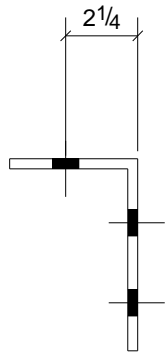

A - A

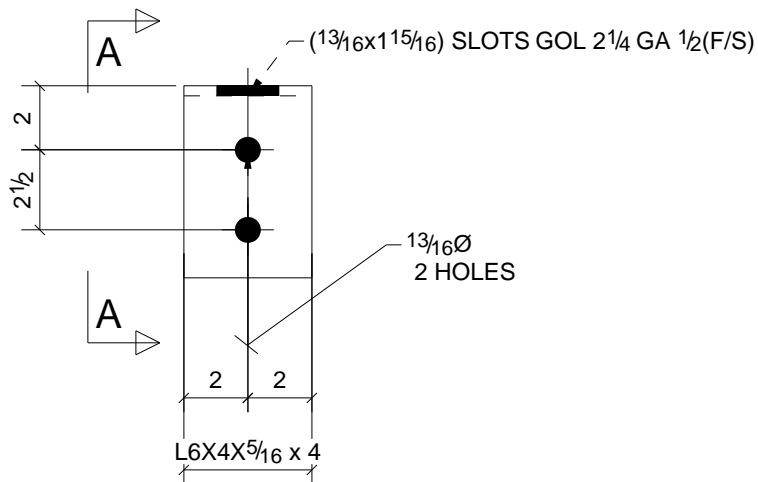

1	C14
Qty.	In Assembly

1	a16	L6X4X5/16	0'-4"		A36
Qty.	Mark	Size	Length	Comments	Grade

PROJECT NAME <b>LITITZ W.W.T.P.</b>	<b>A S P Services Inc</b> Selinsgrove, PA 17870 (570) 374-5333 FAX (570) 374-5335 aspervicesinc.co			
LOCATION <b>WARWICK TWP.-LANCASTER CO., PA</b>				
CUSTOMER <b>PLEASANT MOUNT WELDING, INC.</b>	DESCRIPTION <b>ANGLE</b>	DATE <b>11/03/2009</b>	JOB No. <b>17-052-9</b>	
ARCHITECT <b>ENTECH ENGINEERING, INC.</b>		DRAWN BY <b>TMAC</b>	DRG No. <b>a16</b>	



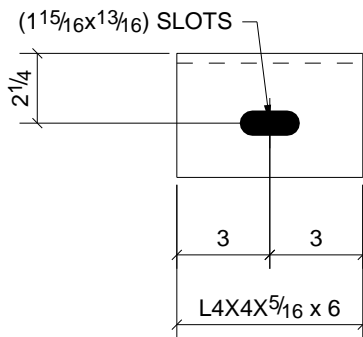

1	C9
1	C14
Qty.	In Assembly

2	a4	L4X4X5/16	0'-6"		A36
Qty.	Mark	Size	Length	Comments	Grade

PROJECT NAME	LITITZ W.W.T.P.
LOCATION	WARWICK TWP.-LANCASTER CO., PA
CUSTOMER	PLEASANT MOUNT WELDING, INC.
ARCHITECT	ENTECH ENGINEERING, INC.

<b>A S P Services Inc</b>	
Selinsgrove, PA 17870	
(570) 374-5333 FAX (570) 374-5335 <a href="http://aspservicesinc.co">aspservicesinc.co</a>	
DESCRIPTION	ANGLE
DATE	06/03/2009
JOB No.	17-052-9
DRAWN BY	TMAC
DRG No.	a4

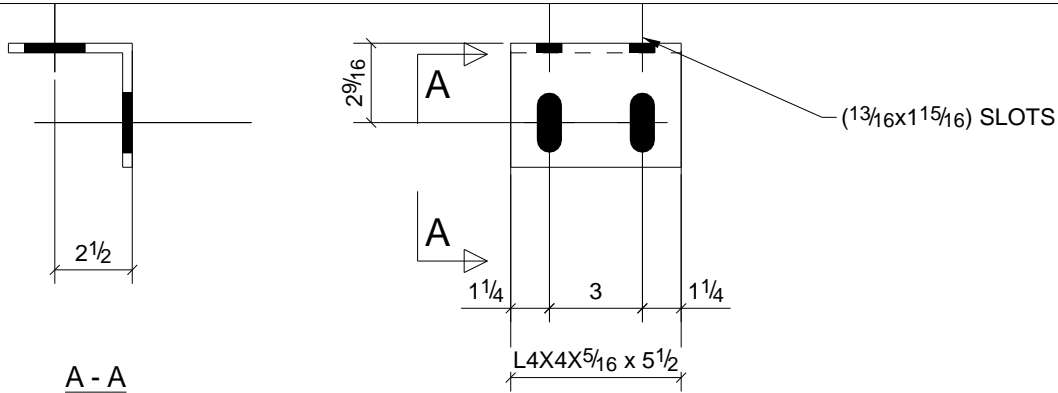

2	B7
Qty.	In Assembly

2	a5	L4X4X5/16	0'-5 1/2"		A36
Qty.	Mark	Size	Length	Comments	Grade

PROJECT NAME	LITITZ W.W.T.P.
LOCATION	WARWICK TWP.-LANCASTER CO., PA
CUSTOMER	PLEASANT MOUNT WELDING, INC.
ARCHITECT	ENTECH ENGINEERING, INC.

<b>A S P Services Inc</b>		
Selinsgrove, PA 17870		
(570) 374-5333 FAX (570) 374-5335 asp-servicesinc.co		
DESCRIPTION	DATE	JOB No.
ANGLE	06/03/2009	17-052-9
	DRAWN BY	DRG No.
		a5

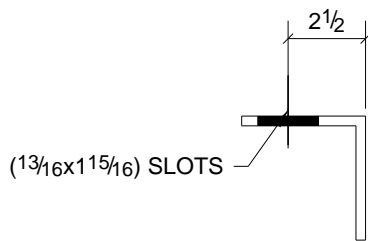

A - A

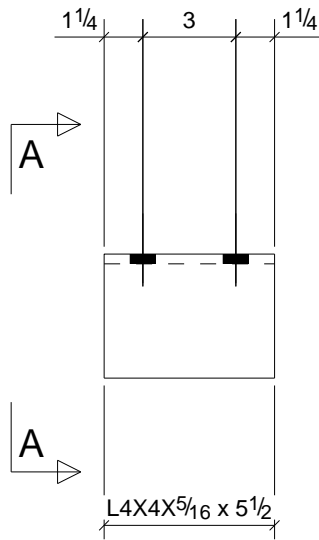

2	B7
Qty.	In Assembly

2	a6	L4X4X5/16	0'-5 1/2"		A36
Qty.	Mark	Size	Length	Comments	Grade

PROJECT NAME	LITITZ W.W.T.P.
LOCATION	WARWICK TWP.-LANCASTER CO., PA
CUSTOMER	PLEASANT MOUNT WELDING, INC.
ARCHITECT	ENTECH ENGINEERING, INC.

<b>A S P Services Inc</b>	
Selinsgrove, PA 17870 (570) 374-5333 FAX (570) 374-5335 <a href="http://aspservicesinc.co">aspservicesinc.co</a>	
DESCRIPTION	ANGLE
DATE	06/03/2009
JOB No.	17-052-9
DRAWN BY	
DRG No.	a6

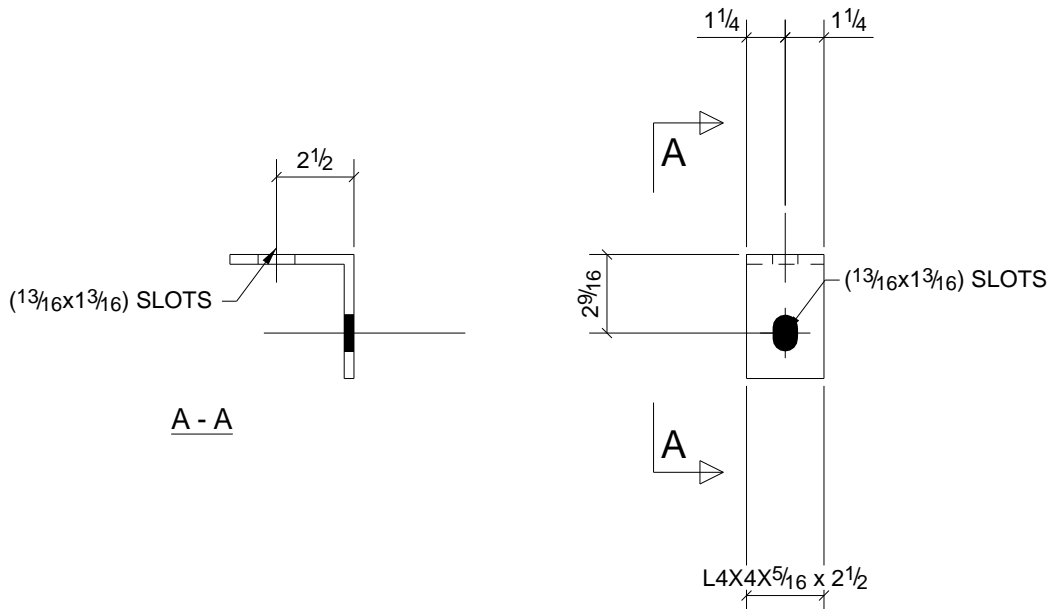

4	C4
Qty.	In Assembly

4	a7	L4X4X5/16	0'-2 1/2"		A36
Qty.	Mark	Size	Length	Comments	Grade

PROJECT NAME	LITITZ W.W.T.P.
LOCATION	WARWICK TWP.-LANCASTER CO., PA
CUSTOMER	PLEASANT MOUNT WELDING, INC.
ARCHITECT	ENTECH ENGINEERING, INC.

<b>A S P Services Inc</b>		
Selinsgrove, PA 17870		
(570) 374-5333 FAX (570) 374-5335 <a href="http://aspservicesinc.co">aspservicesinc.co</a>		
DESCRIPTION	DATE	JOB No.
ANGLE	06/03/2009	17-052-9
	DRAWN BY	DRG No.
		a7

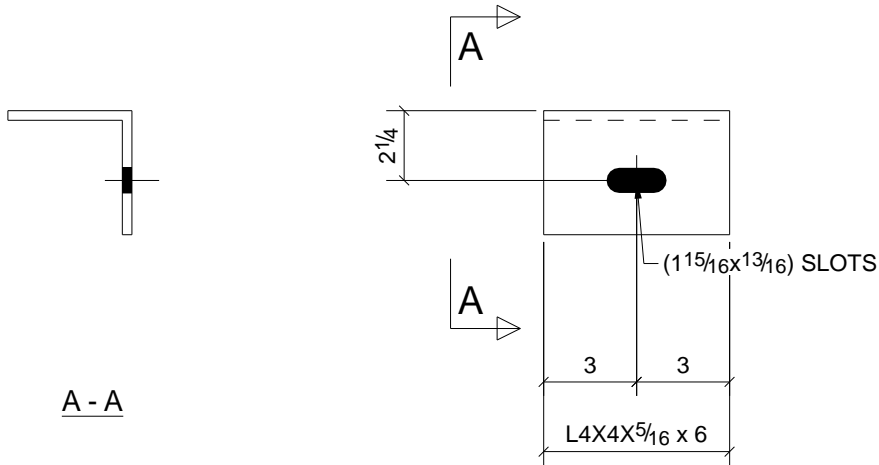

2	C11
2	C14
Qty.	In Assembly

4	a8	L4X4X5/16	0'-6"		A36
Qty.	Mark	Size	Length	Comments	Grade

PROJECT NAME LITITZ W.W.T.P.	<b>A S P Services Inc</b> Selinsgrove, PA 17870 (570) 374-5333 FAX (570) 374-5335 asp-servicesinc.co			
LOCATION WARWICK TWP.-LANCASTER CO., PA				
CUSTOMER PLEASANT MOUNT WELDING, INC.	DESCRIPTION ANGLE	DATE 06/03/2009	JOB No. 17-052-9	
ARCHITECT ENTECH ENGINEERING, INC.		DRAWN BY TMAC	DRG No. a8	

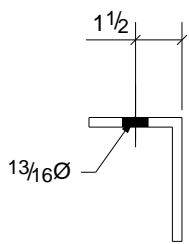

A - A

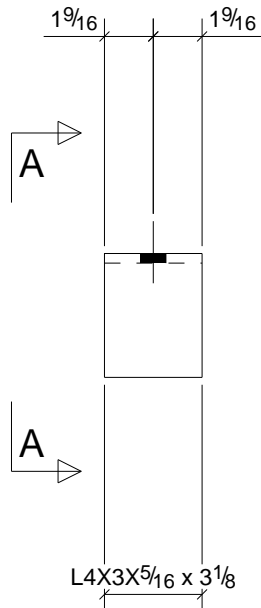

2	C18
2	C19
Qty.	In Assembly

4	a9	L4X3X5/16	0'-3 1/8"		A36
Qty.	Mark	Size	Length	Comments	Grade

PROJECT NAME	LITITZ W.W.T.P.
LOCATION	WARWICK TWP.-LANCASTER CO., PA
CUSTOMER	PLEASANT MOUNT WELDING, INC.
ARCHITECT	ENTECH ENGINEERING, INC.

<b>A S P Services Inc</b>	
Selinsgrove, PA 17870	
(570) 374-5333 FAX (570) 374-5335 asp-servicesinc.co	
DESCRIPTION	ANGLE
DATE	06/03/2009
JOB No.	17-052-9
DRAWN BY	
DRG No.	a9

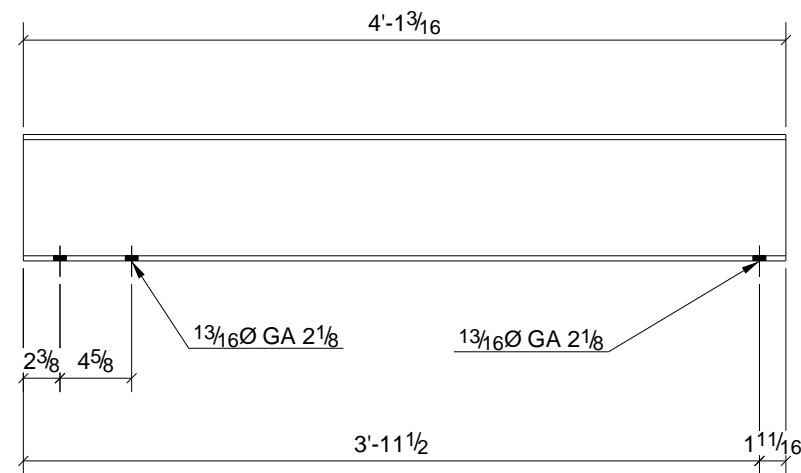

**ONE - BEAM - B6**

10/22/09	△C	For Approval w/ Customer Field Data	TMAC
6/04/09	△B	For Approval	TMAC
5/12/09	△A	For Approval	TMAC
10/30/09	△0	For Fabrication w/ Approver Comments	MT
DATE	NO.	DESCRIPTION	BY

**BILL OF MATERIAL**

Qty Ea.	Qty Tot	Piece Mark	Description	Length	Weight Total	Remarks	Adv Mill #	Steel Grade
	1	B6	BEAM					
1	1		W8X18	4'-1 3/16"	73	SQ-2		A992

STEEL ASTM	A992	UNO	PROJECT NAME	LITITZ W.W.T.P.
ELECTRODES	E70xx LH	UNO	LOCATION	WARWICK TWP.-LANCASTER CO., PA
WELDS	1/4 BUTT/FILLET	UNO	CONTRACTOR	PLEASANT MOUNT WELDING, INC.
OPEN HOLES	13/16"	UNO	ARCHITECT	ENTECH ENGINEERING, INC.
BOLTS	3/4"Ø A325-N-ST	UNO		
PAINT	PER SPECS	UNO		

<b>A S P Services Inc</b> Selinsgrove, PA 17870 (570) 374-5333 FAX (570) 374-5335 aspsservicesinc.com			
DESCRIPTION	DATE	JOB No.	
BEAM ASS'Y	10/21/2009	17-052-9	
	DRAWN BY	DRG No.	
	TMAC	B6	

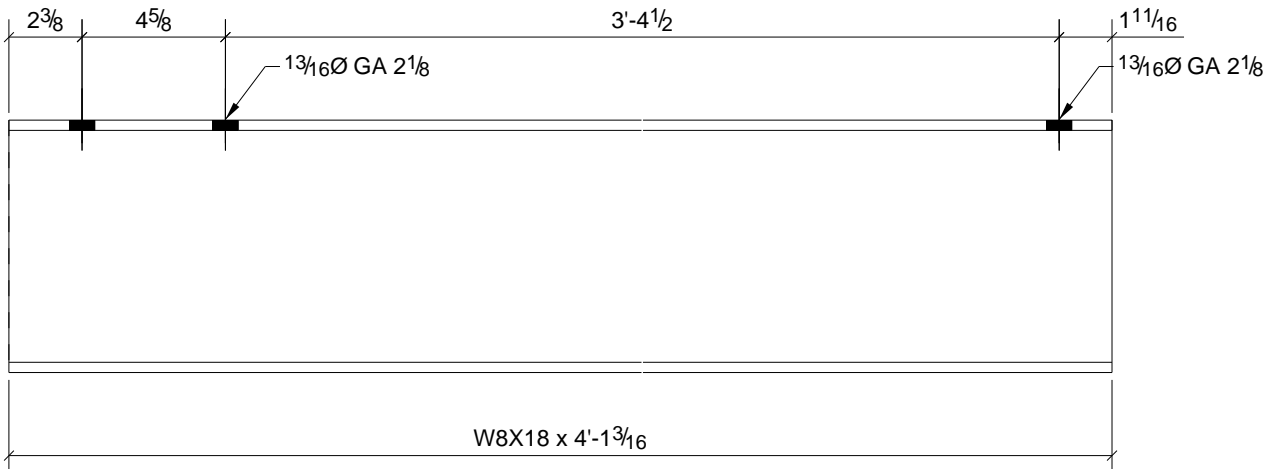

1	B6
Qty.	In Assembly

Qty.	Mark	Size	Length	Comments	Grade
1	B6	W8X18	4'-1 3/16"		A992

PROJECT NAME LITITZ W.W.T.P.		<b>A S P Services Inc</b> Selinsgrove, PA 17870 (570) 374-5333 FAX (570) 374-5335 <a href="http://aspservicesinc.co">aspservicesinc.co</a>			
LOCATION WARWICK TWP.-LANCASTER CO., PA					
CUSTOMER PLEASANT MOUNT WELDING, INC.		DESCRIPTION BEAM	DATE 10/21/2009	JOB No. 17-052-9	
ARCHITECT ENTECH ENGINEERING, INC.			DRAWN BY TMAC	DRG No. B6	



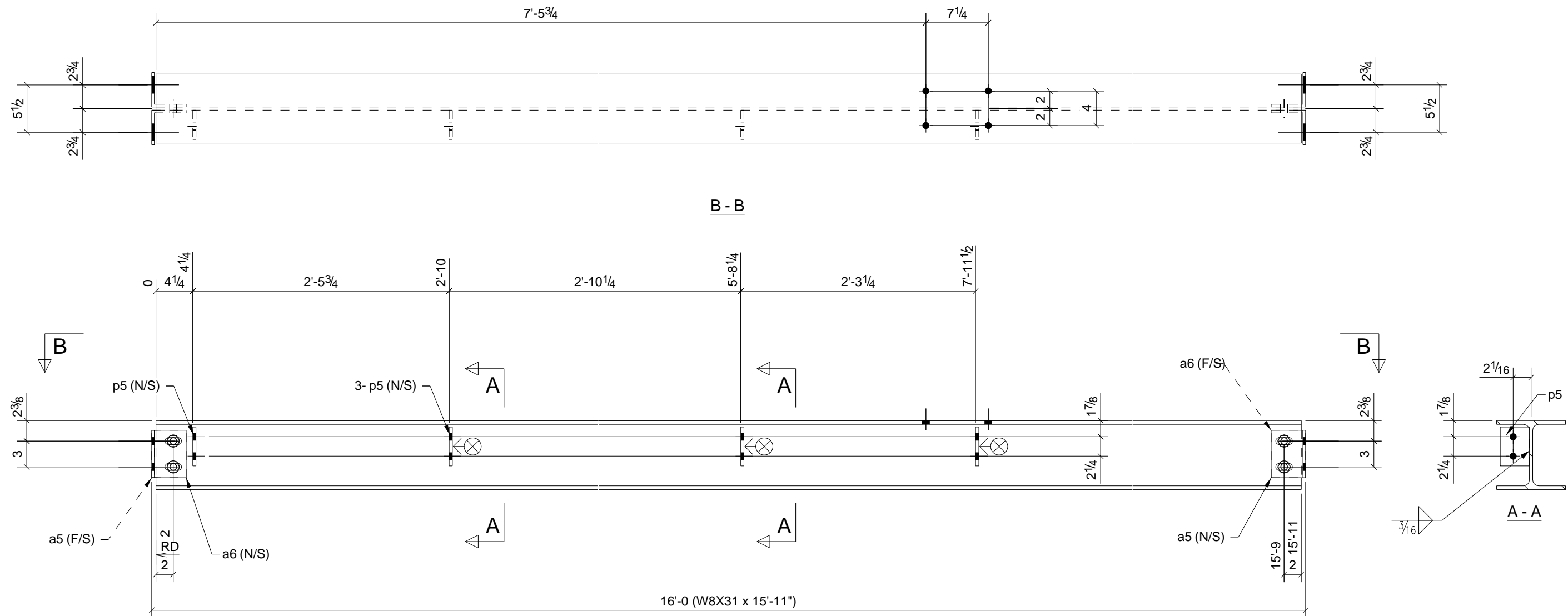

**ONE - BEAM - B7**

**BILL OF MATERIAL**

Qty Ea.	Qty Tot	Piece Mark	Description	Length	Weight Total	Remarks	Adv Mill #	Steel Grade
	1	B7	BEAM					
1	1		W8X31	15'-11"	494	SQ-2		A992
2	2	a5	L4X4X5/16	0'-5 1/2"	7			A36
2	2	a6	L4X4X5/16	0'-5 1/2"	7			A36
4	4	p5	PL3/8"X3 3/8"	0'-4 1/2"	6			A36

STEEL ASTM	A992	UNO	PROJECT NAME	LITITZ W.W.T.P.
ELECTRODES	E70xx LH	UNO	LOCATION	WARWICK TWP.-LANCASTER CO., PA
WELDS	1/4 BUTT/FILLET	UNO	CONTRACTOR	PLEASANT MOUNT WELDING, INC.
OPEN HOLES	13/16"	UNO	ARCHITECT	ENTECH ENGINEERING, INC.
BOLTS	3/4"Ø A325-N-ST	UNO		
PAINT	PER SPECS	UNO		

10/22/09	△C	For Approval w/ Customer Field Data	TMAC
6/04/09	△B	For Approval	TMAC
5/12/09	△A	For Approval	TMAC
10/30/09	△O	For Fabrication w/ Approver Comments	MT
DATE	NO.	DESCRIPTION	BY

**A S P Services Inc**  
 Selinsgrove, PA 17870  
 (570) 374-5333 FAX (570) 374-5335 aspsservicesinc.com

DESCRIPTION	DATE	JOB No.
BEAM ASS'Y	10/21/2009	17-052-9
	DRAWN BY	DRG No.
	TMAC	B7

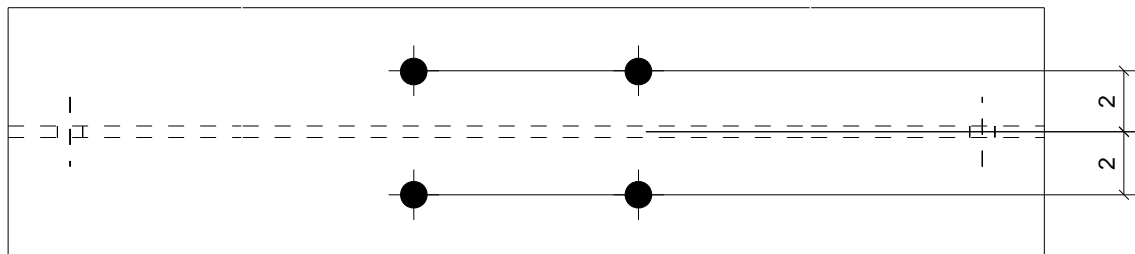
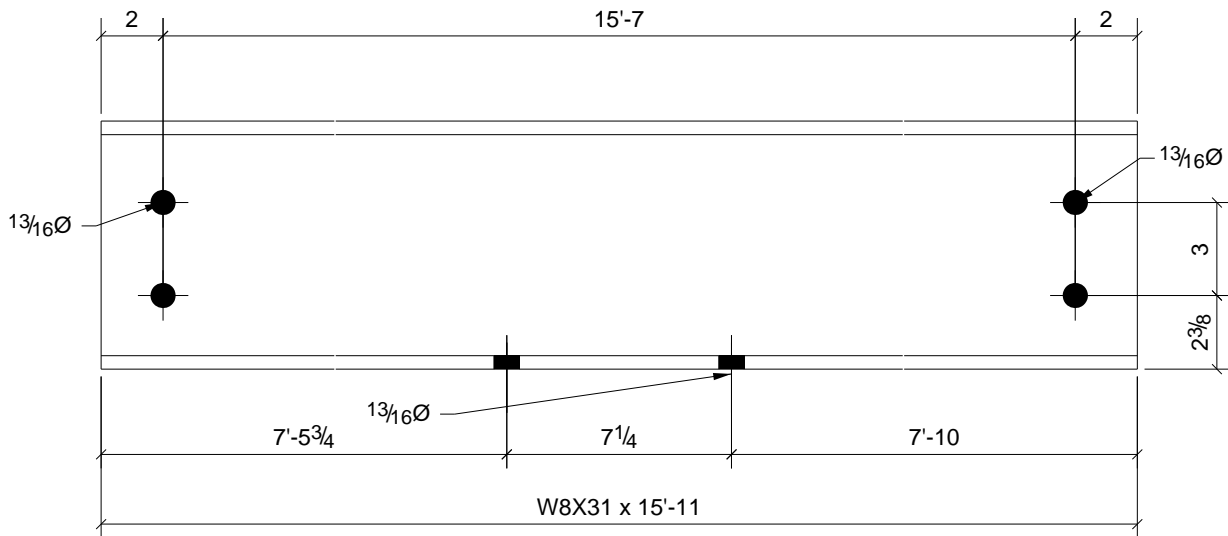

1	B7
Qty.	In Assembly

1	B7	W8X31	15'-11"		A992
Qty.	Mark	Size	Length	Comments	Grade

PROJECT NAME	LITITZ W.W.T.P.
LOCATION	WARWICK TWP.-LANCASTER CO., PA
CUSTOMER	PLEASANT MOUNT WELDING, INC.
ARCHITECT	ENTECH ENGINEERING, INC.

<b>A S P Services Inc</b>		
Selinsgrove, PA 17870		
(570) 374-5333 FAX (570) 374-5335 asp-servicesinc.co		
DESCRIPTION	DATE	JOB No.
BEAM	10/21/2009	17-052-9
	DRAWN BY	DRG No.
	TMAC	B7

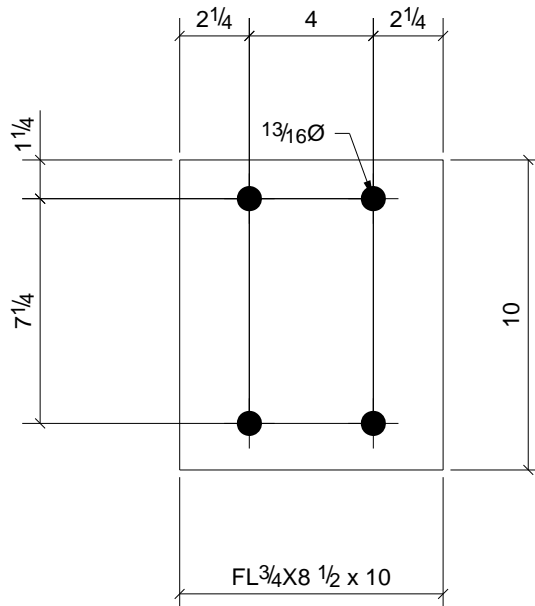

1	C14
Qty.	In Assembly

1	BP3	FL 3/4" X 8 1/2"	0'-10"		A36
Qty.	Mark	Size	Length	Comments	Grade

PROJECT NAME	LITITZ W.W.T.P.
LOCATION	WARWICK TWP.-LANCASTER CO., PA
CUSTOMER	PLEASANT MOUNT WELDING, INC.
ARCHITECT	ENTECH ENGINEERING, INC.

<b>A S P Services Inc</b>	
Selinsgrove, PA 17870 (570) 374-5333 FAX (570) 374-5335 <a href="http://aspservicesinc.co">aspservicesinc.co</a>	
DESCRIPTION	PLATE
DATE	11/02/2009
JOB No.	17-052-9
DRAWN BY	TMAC
DRG No.	BP3

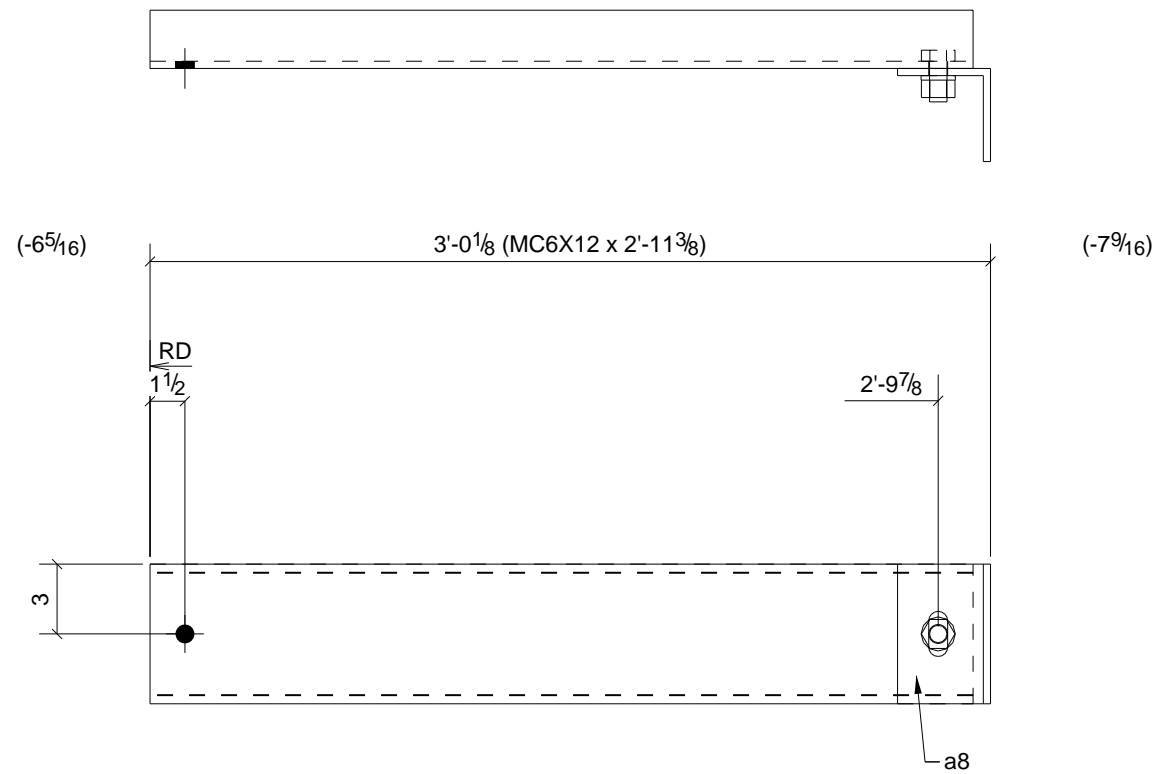

**2 - BEAMS - C11**

10/22/09	△C	For Approval w/ Customer FieldData	TMAC
6/04/09	△B	For Approval	TMAC
5/12/09	△A	For Approval	TMAC
10/30/09	△0	For Fabrication w/ Approver Comments	MT
DATE	NO.	DESCRIPTION	BY

**BILL OF MATERIAL**

Qty Ea.	Qty Tot	Piece Mark	Description	Length	Weight Total	Remarks	Adv Mill #	Steel Grade
	2	C11	BEAMS					
2	2		MC6X12	2'-11 3/8"	71	SQ-2		A36
1	2	a8	L4X4X5/16	0'-6"	8			A36

STEEL ASTM	A992	UNO	PROJECT NAME	LITITZ W.W.T.P.
ELECTRODES	E70xx LH	UNO	LOCATION	WARWICK TWP.-LANCASTER CO., PA
WELDS	1/4 BUTT/FILLET	UNO	CONTRACTOR	PLEASANT MOUNT WELDING, INC.
OPEN HOLES	13/16"	UNO	ARCHITECT	ENTECH ENGINEERING, INC.
BOLTS	3/4"Ø A325-N-ST	UNO		
PAINT	PER SPECS	UNO		

<b>A S P Services Inc</b> Selinsgrove, PA 17870 (570) 374-5333 FAX (570) 374-5335 aspsservicesinc.com		
DESCRIPTION	DATE	JOB No.
CHANNEL ASS'Y	11/02/2009	17-052-9
	DRAWN BY	DRG No.
	TMAC	C11

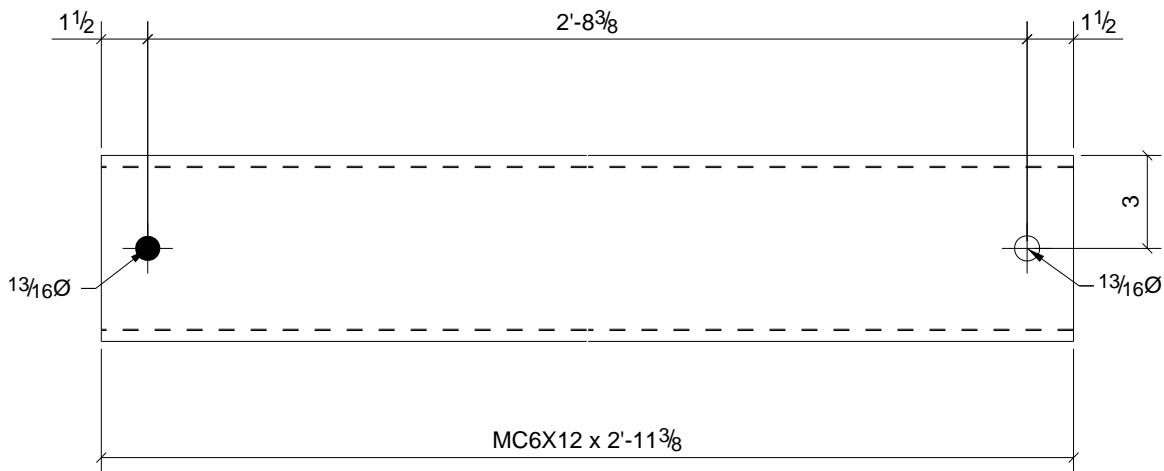

2	C11
Qty.	In Assembly

2	C11	MC6X12	2'-11 3/8"		A36
Qty.	Mark	Size	Length	Comments	Grade

PROJECT NAME	LITITZ W.W.T.P.
LOCATION	WARWICK TWP.-LANCASTER CO., PA
CUSTOMER	PLEASANT MOUNT WELDING, INC.
ARCHITECT	ENTECH ENGINEERING, INC.

<b>A S P Services Inc</b>		
Selinsgrove, PA 17870		
(570) 374-5333 FAX (570) 374-5335 asp-servicesinc.co		
DESCRIPTION	DATE	JOB No.
STANDARD	11/03/2009	17-052-9
	DRAWN BY	DRG No.
TMAC		C11

GRID LOCATION	BOTTOM ELEVATION
3>/E>	354'-9"3/4

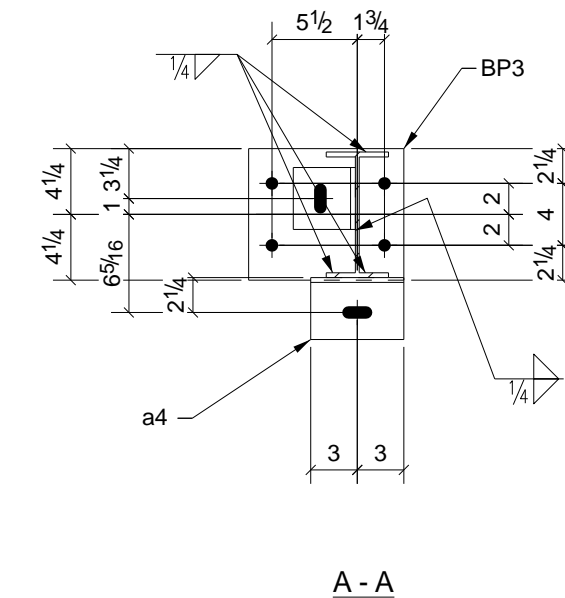
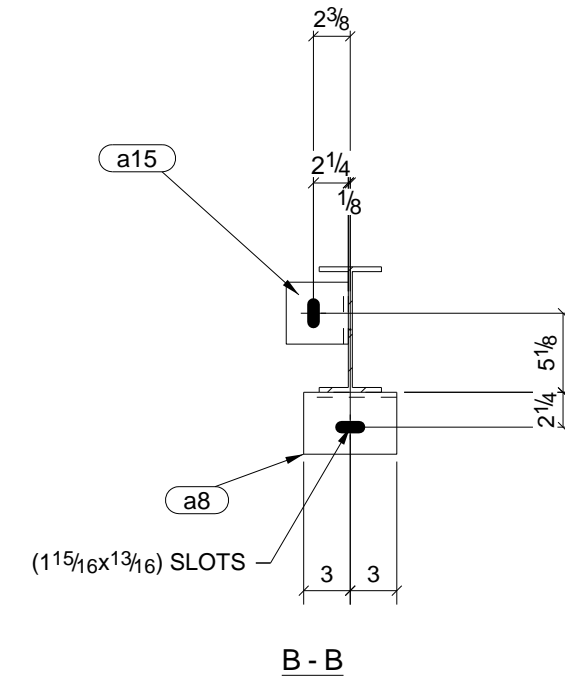
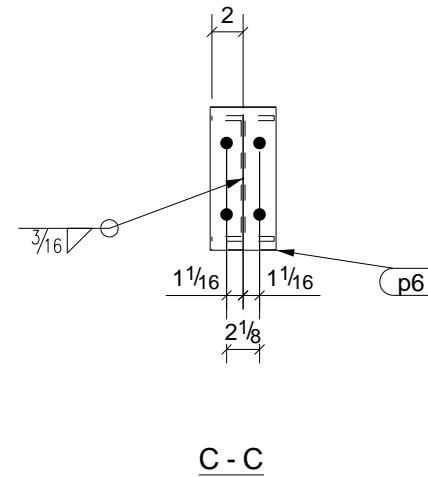
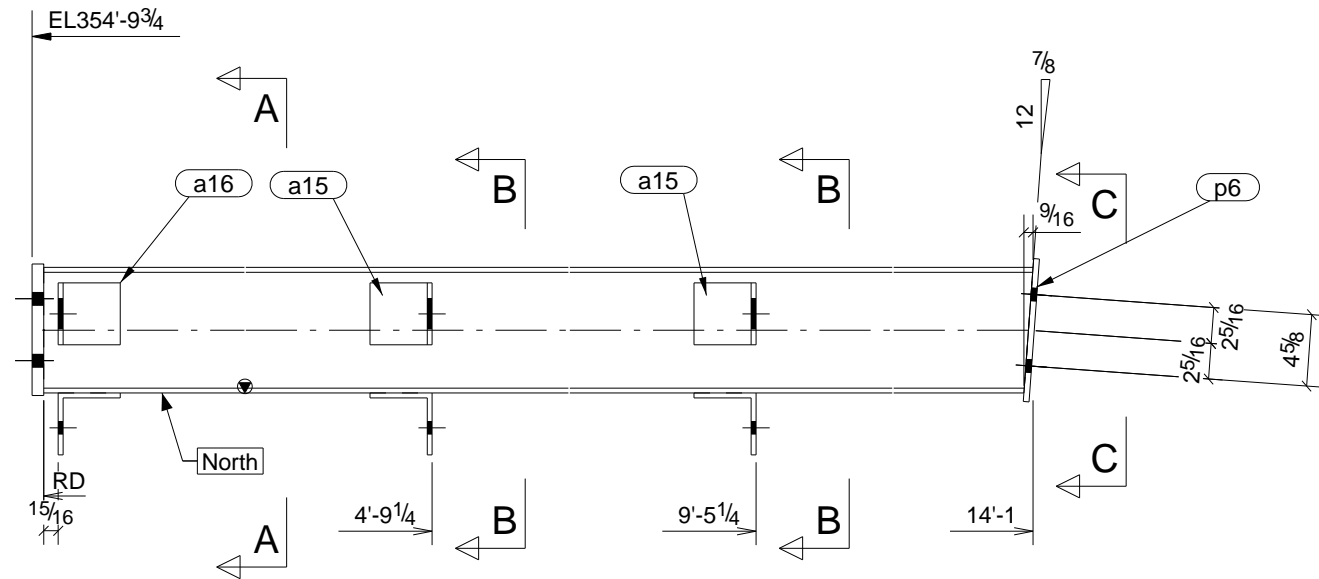
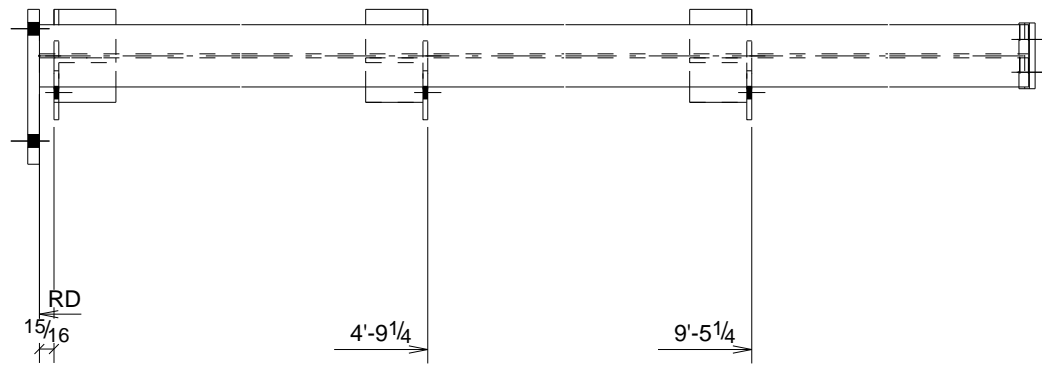

## ONE - COLUMN - C14

### BILL OF MATERIAL

Qty Ea.	Qty Tot	Piece Mark	Description	Length	Weight Total	Remarks	Adv Mill #	Steel Grade
	1	C14	COLUMN					
1	1		W8X15	14'-1"	213	SQ-1/BEV-1		A992
1	1	BP3	FL3/4"X8 1/2"	0'-10"	18			A36
1	1	a4	L4X4X5/16	0'-6"	4			A36
2	2	a8	L4X4X5/16	0'-6"	8			A36
2	2	a15	L4X4X5/16	0'-4"	5			A36
1	1	a16	L4X4X5/16	0'-4"	3			A36
1	1	p6	FL3/8"X4 1/4"	0'-9 1/4"	4			A36

STEEL ASTM	A992	UNO	PROJECT NAME	LITITZ W.W.T.P.
ELECTRODES	E70xx LH	UNO	LOCATION	WARWICK TWP.-LANCASTER CO., PA
WELDS	1/4 BUTT/FILLET	UNO	CONTRACTOR	PLEASANT MOUNT WELDING, INC.
OPEN HOLES	13/16"	UNO	ARCHITECT	ENTECH ENGINEERING, INC.
BOLTS	3/4"Ø A325-N-ST	UNO		
PAINT	PER SPECS	UNO		

10/22/09	△ C	For Approval w/ Customer Field Data	TMAC
6/04/09	△ B	For Approval	TMAC
5/12/09	△ A	For Approval	TMAC
10/30/09	△ 0	For Fabrication w/ Approver Comments	MT
DATE	NO.	DESCRIPTION	BY

**A S P Services Inc**  
Selinsgrove, PA 17870

(570) 374-5333 FAX (570) 374-5335 asp-services-inc.com

DESCRIPTION	DATE	JOB No.
COLUMN ASS'Y	10/21/2009	17-052-9
	DRAWN BY	DRG No.
	TMAC	C14

GRID LOCATION	BOTTOM ELEVATION
3>E>	354'-9"3/4

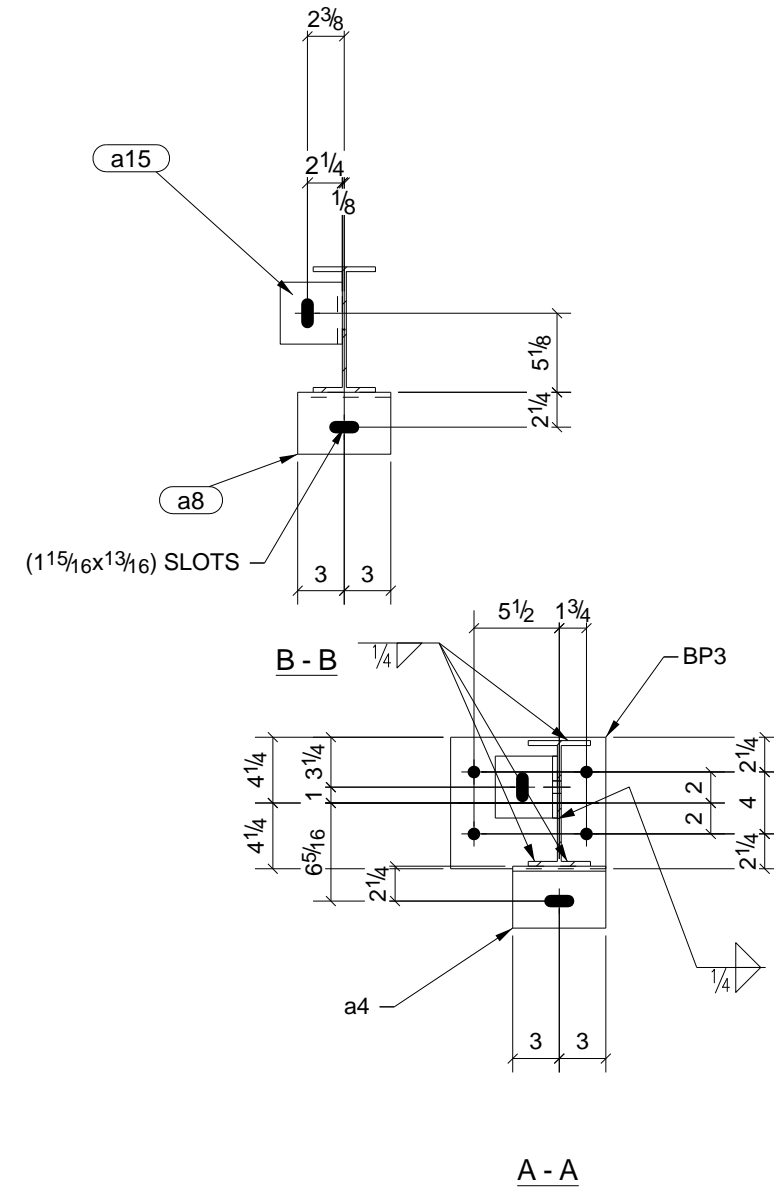
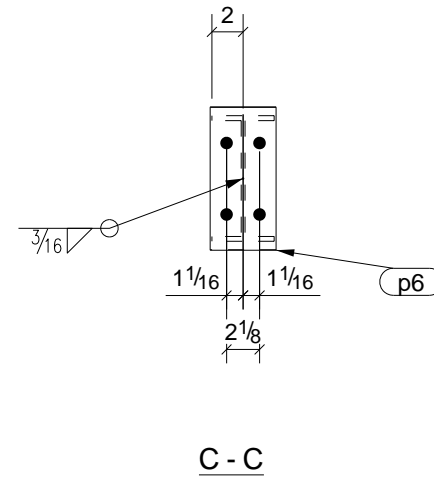
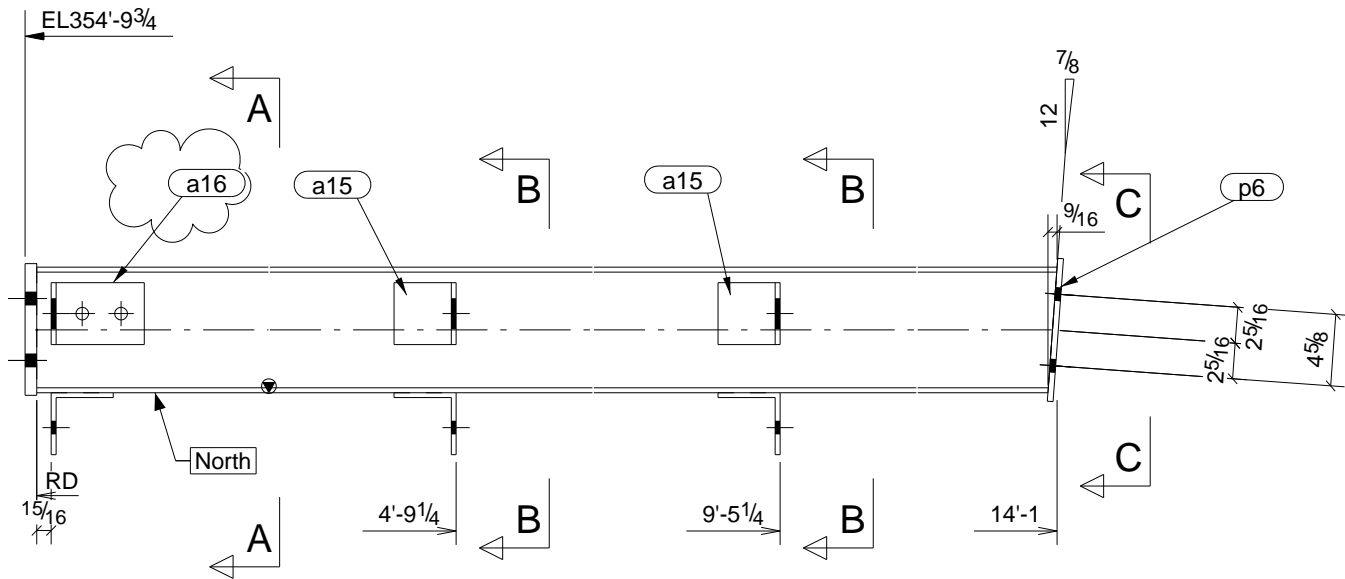
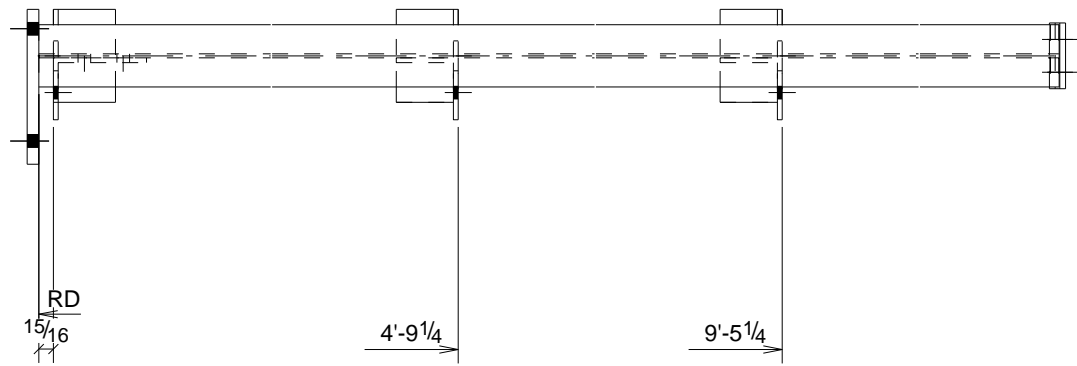

## ONE - COLUMN - C14

### BILL OF MATERIAL

Qty Ea.	Qty Tot	Piece Mark	Description	Length	Weight Total	Remarks	Adv Mill #	Steel Grade
	1	C14	COLUMN					
1	1		W8X15	14'-1"	213	SQ-1/BEV-1		A992
1	1	BP3	FL3/4"X8 1/2"	0'-10"	18			A36
1	1	a4	L4X4X5/16	0'-6"	4			A36
2	2	a8	L4X4X5/16	0'-6"	8			A36
2	2	a15	L4X4X5/16	0'-4"	5			A36
1	1	a16	L6X4X5/16	0'-4"	3			A36
1	1	p6	FL3/8"X4 1/4"	0'-9 1/4"	4			A36
2	2		3/4"Ø A325N BOLT	0'-1 3/4"	1			

STEEL ASTM	A992	UNO	PROJECT NAME	LITITZ W.W.T.P.
ELECTRODES	E70xx LH	UNO	LOCATION	WARWICK TWP.-LANCASTER CO., PA
WELDS	1/4 BUTT/FILLET	UNO	CONTRACTOR	PLEASANT MOUNT WELDING, INC.
OPEN HOLES	13/16"	UNO	ARCHITECT	ENTECH ENGINEERING, INC.
BOLTS	3/4"Ø A325-N-ST	UNO		
PAINT	PER SPECS	UNO		

10/22/09	△ C	For Approval w/Customer Field Data	TMAC
6/04/09	△ B	For Approval	TMAC
5/12/09	△ A	For Approval	TMAC
11/11/09	△ 1	For Fabrication w/ Shop Changes	MT
10/30/09	△ 0	For Fabrication w/ Approver Comments	MT
DATE	NO.	DESCRIPTION	BY

**A S P Services Inc**  
 Selinsgrove, PA 17870  
 (570) 374-5333 FAX (570) 374-5335 asp-servicesinc.com

DESCRIPTION	DATE	JOB No.
COLUMN ASS'Y	10/21/2009	17-052-9
	DRAWN BY	DRG No.
	TMAC	C14

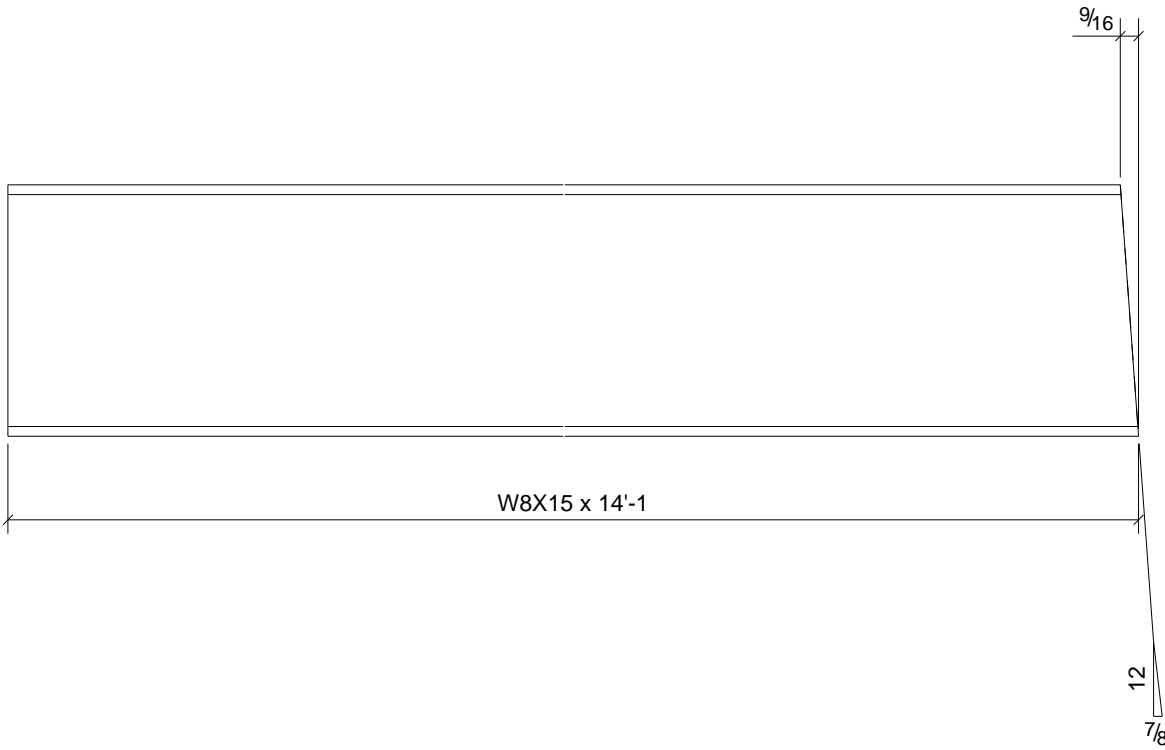

1	C14
Qty.	In Assembly

1	C14	W8X15	14'-1"		A992
Qty.	Mark	Size	Length	Comments	Grade

PROJECT NAME	LITITZ W.W.T.P.
LOCATION	WARWICK TWP.-LANCASTER CO., PA
CUSTOMER	PLEASANT MOUNT WELDING, INC.
ARCHITECT	ENTECH ENGINEERING, INC.

<b>A S P Services Inc</b>		
Selinsgrove, PA 17870		
(570) 374-5333 FAX (570) 374-5335 <a href="http://aspservicesinc.co">aspservicesinc.co</a>		
DESCRIPTION	DATE	JOB No.
COLUMN	10/21/2009	17-052-9
	DRAWN BY	DRG No.
	TMAC	C14



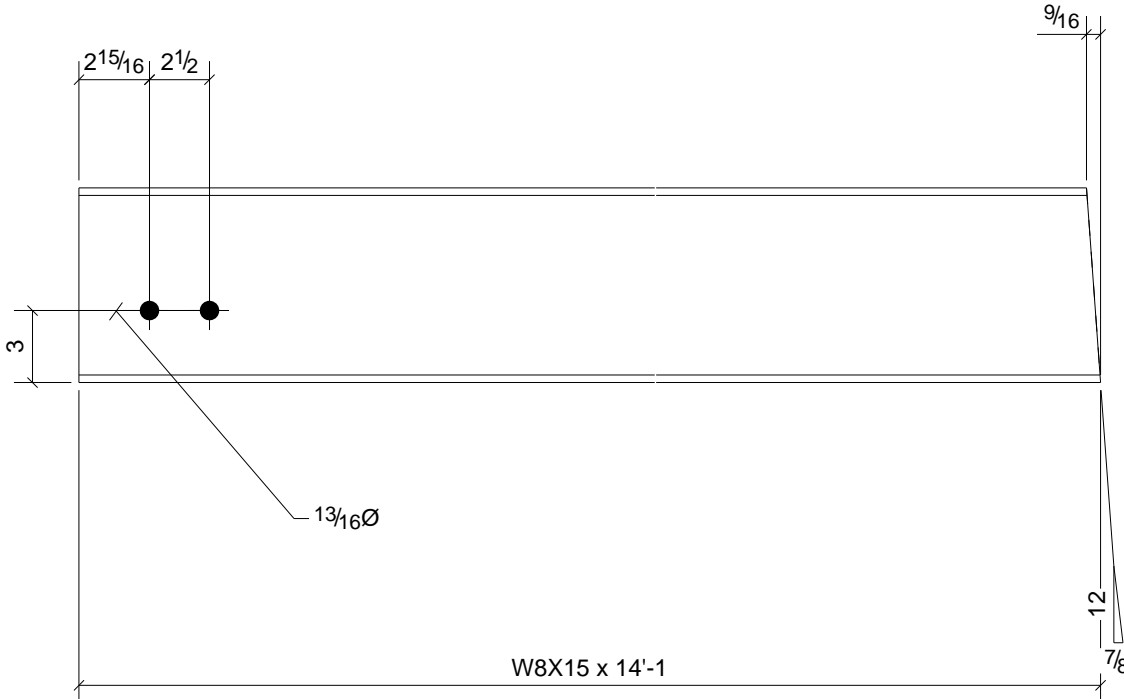

W8X15 x 14'-1

1	C14
Qty.	In Assembly

1	C14	W8X15	14'-1"		A992
Qty.	Mark	Size	Length	Comments	Grade

PROJECT NAME <b>LITITZ W.W.T.P.</b>	<b>A S P Services Inc</b> Selinsgrove, PA 17870 (570) 374-5333 FAX (570) 374-5335 <a href="http://aspservicesinc.co">aspservicesinc.co</a>			
LOCATION <b>WARWICK TWP.-LANCASTER CO., PA</b>				
CUSTOMER <b>PLEASANT MOUNT WELDING, INC.</b>	DESCRIPTION <b>COLUMN</b>	DATE <b>10/21/2009</b>	JOB No. <b>17-052-9</b>	
ARCHITECT <b>ENTECH ENGINEERING, INC.</b>		DRAWN BY <b>TMAC</b>	DRG No. <b>C14</b>	

GRID LOCATION	BOTTOM ELEVATION
3>/E>	364'-5"1/16

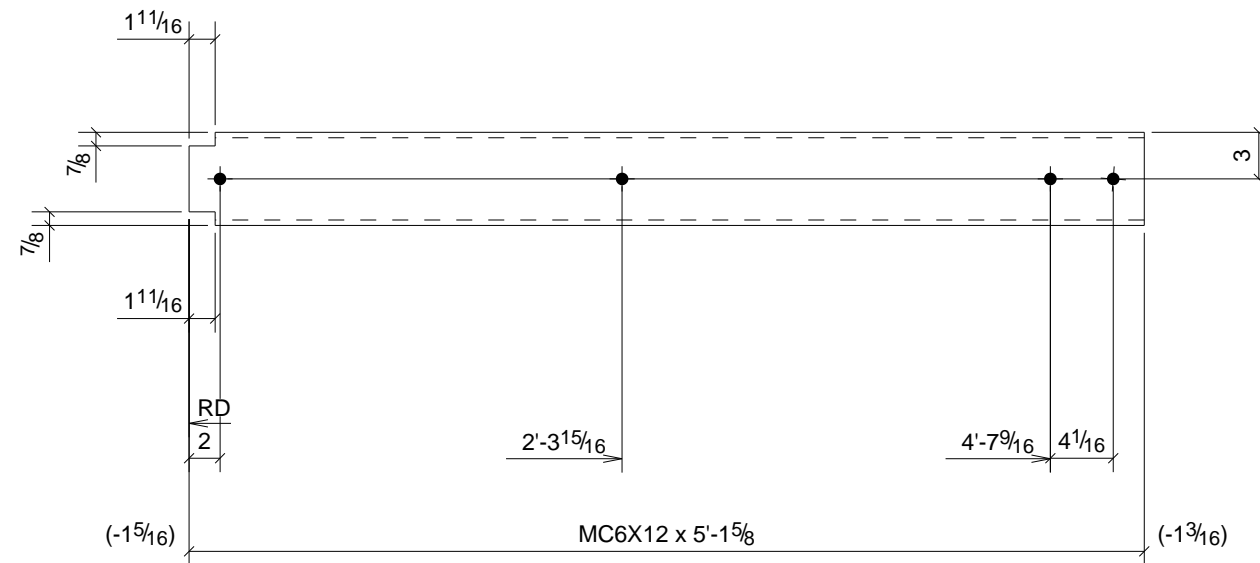

### ONE - BEAM - C15

10/22/09	△	For Approval w/ Customer Field Data	TMAC
10/30/09	△	For Fabrication w/ Approver Comments	MT
DATE	NO.	DESCRIPTION	BY

### BILL OF MATERIAL

Qty Ea.	Qty Tot	Piece Mark	Description	Length	Weight Total	Remarks	Adv Mill #	Steel Grade
	1	C15	BEAM					
1	1		MC6X12	5'-1 5/8"	62	SQ-2		A36

STEEL ASTM	A992	UNO	PROJECT NAME	LITITZ W.W.T.P.
ELECTRODES	E70xx LH	UNO	LOCATION	WARWICK TWP.-LANCASTER CO., PA
WELDS	1/4 BUTT/FILLET	UNO	CONTRACTOR	PLEASANT MOUNT WELDING, INC.
OPEN HOLES	13/16"	UNO	ARCHITECT	ENTECH ENGINEERING, INC.
BOLTS	3/4"Ø A325-N-ST	UNO		
PAINT	PER SPECS	UNO		

**A S P Services Inc**  
Selinsgrove, PA 17870  
(570) 374-5333 FAX (570) 374-5335 aspservicesinc.com

DESCRIPTION	DATE	JOB No.
CHANNEL ASS'Y	10/22/2009	17-052-9
	DRAWN BY	DRG No.
	TMAC	C15

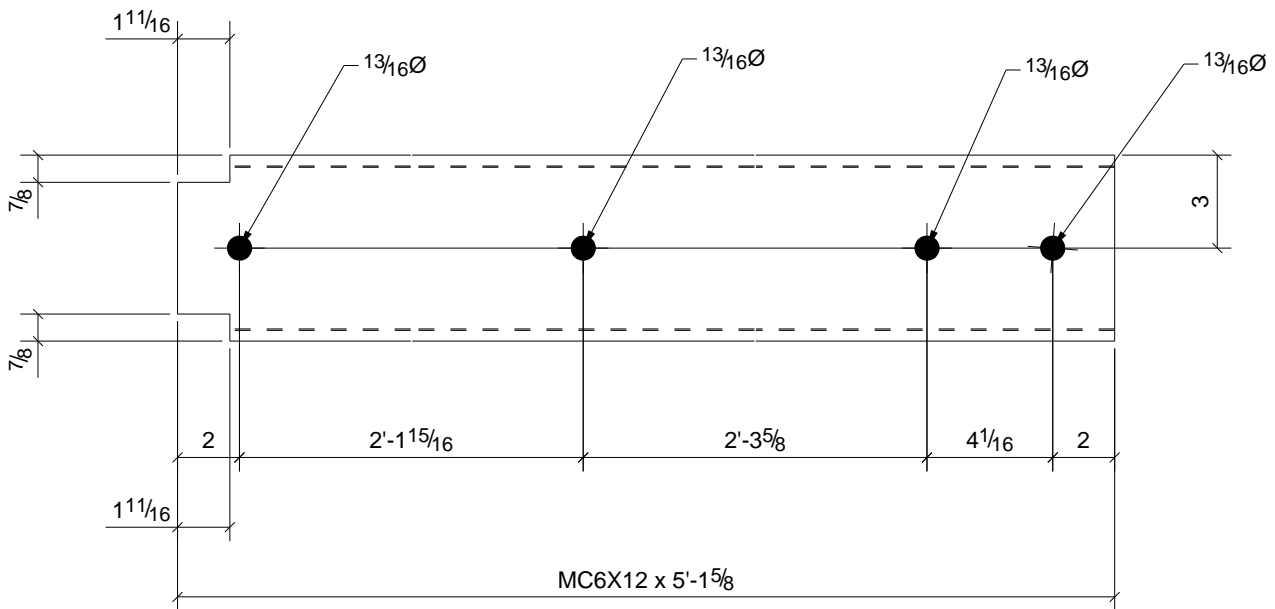

1	C15
Qty.	In Assembly

Qty.	Mark	Size	Length	Comments	Grade
1	C15	MC6X12	5'-1 5/8"		A36

PROJECT NAME	LITITZ W.W.T.P.
LOCATION	WARWICK TWP.-LANCASTER CO., PA
CUSTOMER	PLEASANT MOUNT WELDING, INC.
ARCHITECT	ENTECH ENGINEERING, INC.

<b>A S P Services Inc</b>		
Selinsgrove, PA 17870		
(570) 374-5333 FAX (570) 374-5335 asp-servicesinc.co		
DESCRIPTION	DATE	JOB No.
CHANNEL	11/03/2009	17-052-9
	DRAWN BY	DRG No.
TMAC		C15

GRID LOCATION	BOTTOM ELEVATION
3>/E>	364'-5"1/16

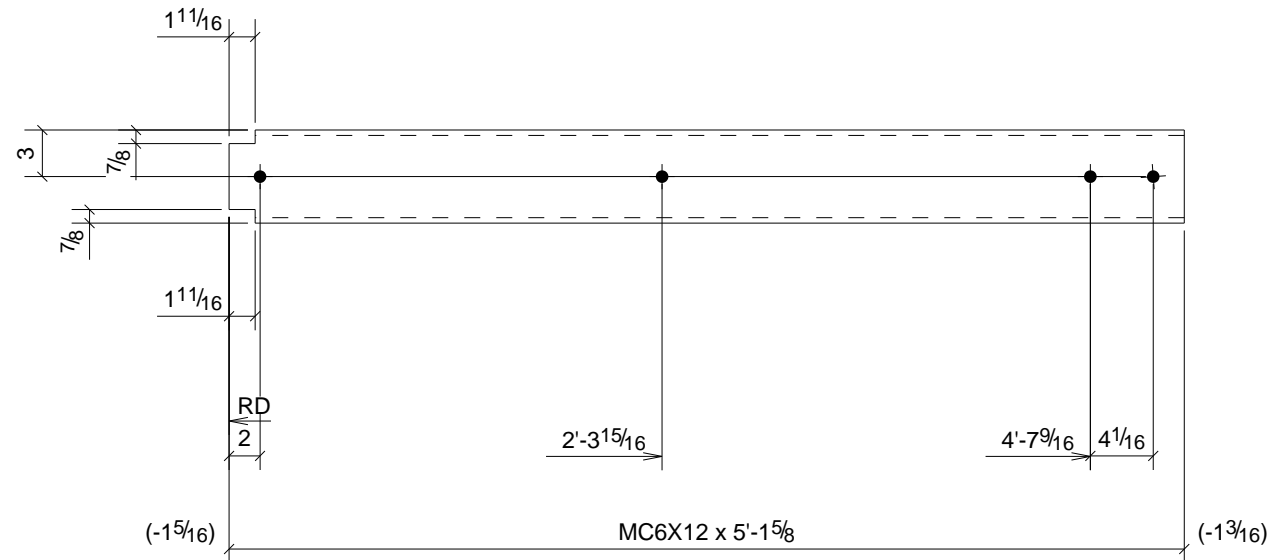

## ONE - BEAM - C16

10/22/09	△	For Approval w/ Customer Field Data	TMAC
10/30/09	△	For Fabrication w/ Approver Comments	MT
DATE	NO.	DESCRIPTION	BY

### BILL OF MATERIAL

Qty Ea.	Qty Tot	Piece Mark	Description	Length	Weight Total	Remarks	Adv Mill #	Steel Grade
	1	C16	BEAM					
1	1		MC6X12	5'-1 5/8"	62	SQ-2		A36

STEEL ASTM	A992	UNO	PROJECT NAME	LITITZ W.W.T.P.
ELECTRODES	E70xx LH	UNO	LOCATION	WARWICK TWP.-LANCASTER CO., PA
WELDS	1/4 BUTT/FILLET	UNO	CONTRACTOR	PLEASANT MOUNT WELDING, INC.
OPEN HOLES	13/16"	UNO	ARCHITECT	ENTECH ENGINEERING, INC.
BOLTS	3/4"Ø A325-N-ST	UNO		
PAINT	PER SPECS	UNO		

<b>A S P Services Inc</b> Selinsgrove, PA 17870 (570) 374-5333 FAX (570) 374-5335 asp-services-inc.com			
DESCRIPTION	DATE	JOB No.	
CHANNEL ASS'Y	10/22/2009	17-052-9	
	DRAWN BY	DRG No.	
	TMAC	C16	

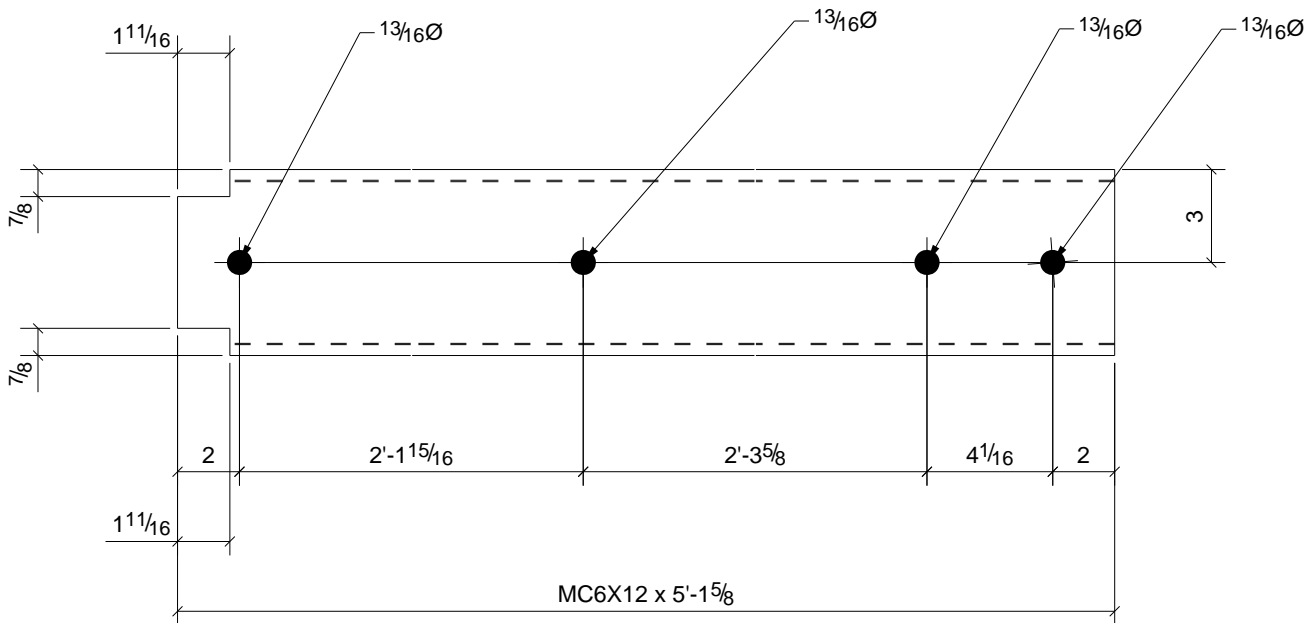

1	C16
Qty.	In Assembly

1	C16	MC6X12	5'-1 5/8"		A36
Qty.	Mark	Size	Length	Comments	Grade

PROJECT NAME	LITITZ W.W.T.P.
LOCATION	WARWICK TWP.-LANCASTER CO., PA
CUSTOMER	PLEASANT MOUNT WELDING, INC.
ARCHITECT	ENTECH ENGINEERING, INC.

<b>A S P Services Inc</b>		
Selinsgrove, PA 17870		
(570) 374-5333 FAX (570) 374-5335 asp-servicesinc.co		
DESCRIPTION	DATE	JOB No.
CHANNEL	11/03/2009	17-052-9
	DRAWN BY	DRG No.
TMAC		C16

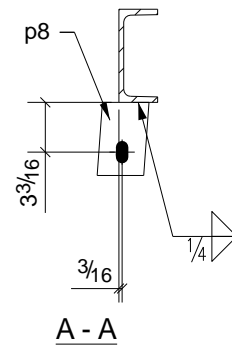
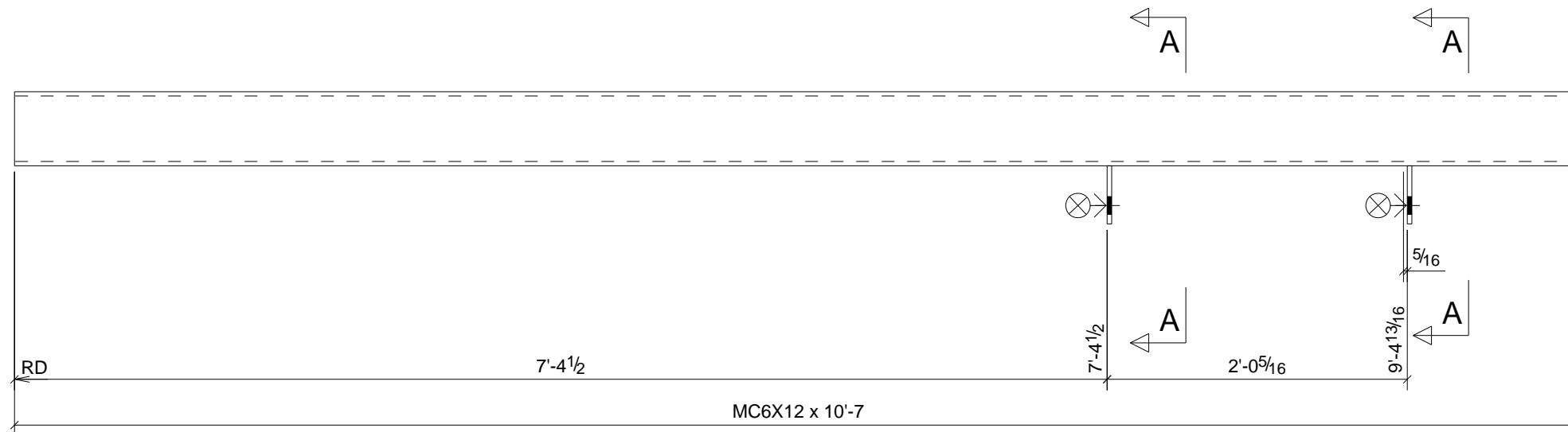

ONE - CHANNEL - C17

10/22/09	△	For Approval w/ Customer Field Data	TMAC
10/30/09	△	For Fabrication w/ Approver Comments	MT
DATE	NO.	DESCRIPTION	BY

**BILL OF MATERIAL**

Qty Ea.	Qty Tot	Piece Mark	Description	Length	Weight Total	Remarks	Adv Mill #	Steel Grade
	1	C17	CHANNEL					
1	1		MC6X12	10'-7"	127	SQ-2		A36
2	2	p8	FL3/8"X3"	0'-4 15/16"	3			A36

STEEL ASTM	A992	UNO
ELECTRODES	E70xx LH	UNO
WELDS	1/4 BUTT/FILLET	UNO
OPEN HOLES	13/16"	UNO
BOLTS	3/4"Ø A325-N-ST	UNO
PAINT	PER SPECS	UNO

PROJECT NAME	LITITZ W.W.T.P.
LOCATION	WARWICK TWP.-LANCASTER CO., PA
CONTRACTOR	PLEASANT MOUNT WELDING, INC.
ARCHITECT	ENTECH ENGINEERING, INC.

<b>A S P Services Inc</b> Selinsgrove, PA 17870 (570) 374-5333 FAX (570) 374-5335 asp-services-inc.com		
DESCRIPTION	DATE	JOB No.
CHANNEL ASS'Y	10/22/2009	17-052-9
	DRAWN BY	DRG No.
	TMAC	C17

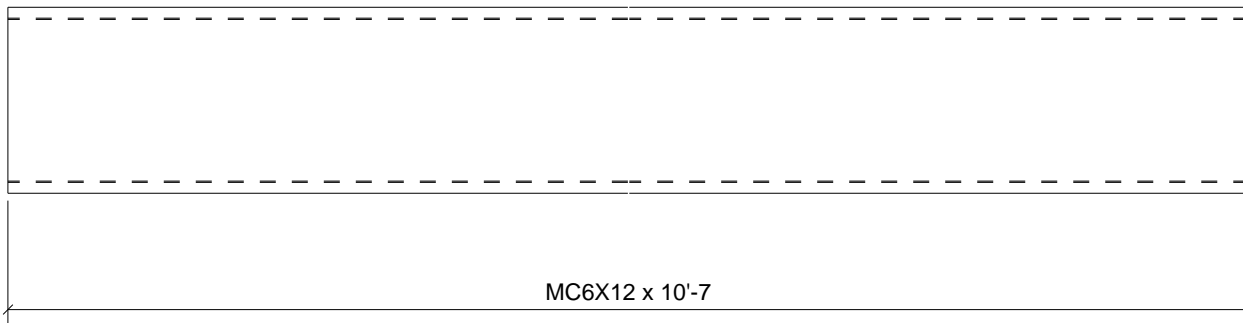

1	C17
Qty.	In Assembly

1	C17	MC6X12	10'-7"		A36
Qty.	Mark	Size	Length	Comments	Grade

PROJECT NAME	LITITZ W.W.T.P.
LOCATION	WARWICK TWP.-LANCASTER CO., PA
CUSTOMER	PLEASANT MOUNT WELDING, INC.
ARCHITECT	ENTECH ENGINEERING, INC.

<b>A S P Services Inc</b>		
Selinsgrove, PA 17870		
(570) 374-5333 FAX (570) 374-5335 <a href="http://aspservicesinc.co">aspservicesinc.co</a>		
DESCRIPTION	DATE	JOB No.
CHANNEL	11/03/2009	17-052-9
	DRAWN BY	DRG No.
	TMAC	C17

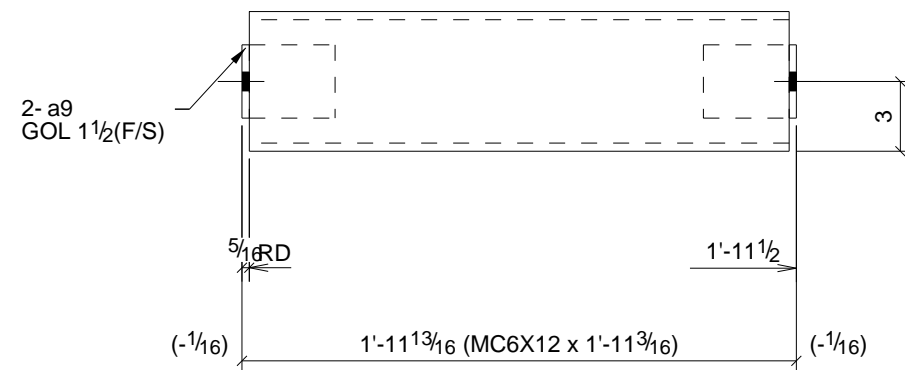

## ONE - BEAM - C18

10/22/09	△	For Approval w/ Customer Field Data	TMAC
10/30/09	△	For Fabrication w/ Approver Comments	MT
DATE	NO.	DESCRIPTION	BY

### BILL OF MATERIAL

Qty Ea.	Qty Tot	Piece Mark	Description	Length	Weight Total	Remarks	Adv Mill #	Steel Grade
	1	C18	BEAM					
1	1		MC6X12	1'-11 3/16"	23	SQ-2		A36
2	2	a9	L4X3X5/16	0'-3 1/8"	4			A36

STEEL ASTM	A992	UNO	PROJECT NAME	LITITZ W.W.T.P.
ELECTRODES	E70xx LH	UNO	LOCATION	WARWICK TWP.-LANCASTER CO., PA
WELDS	1/4 BUTT/FILLET	UNO	CONTRACTOR	PLEASANT MOUNT WELDING, INC.
OPEN HOLES	13/16"	UNO	ARCHITECT	ENTECH ENGINEERING, INC.
BOLTS	3/4"Ø A325-N-ST	UNO		
PAINT	PER SPECS	UNO		

<b>A S P Services Inc</b>	
Selinsgrove, PA 17870	
(570) 374-5333 FAX (570) 374-5335 aspsservicesinc.com	
DESCRIPTION	CHANNEL ASS'Y
DATE	10/22/2009
DRAWN BY	TMAC
JOB No.	17-052-9
DRG No.	C18



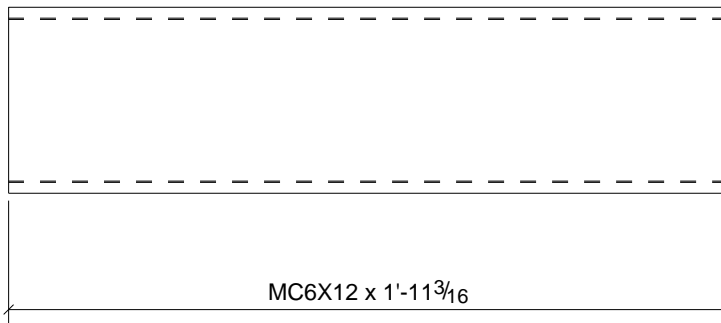

1	C18
Qty.	In Assembly

Qty.	Mark	Size	Length	Comments	Grade
1	C18	MC6X12	1'-11 3/16"		A36

PROJECT NAME	LITITZ W.W.T.P.
LOCATION	WARWICK TWP.-LANCASTER CO., PA
CUSTOMER	PLEASANT MOUNT WELDING, INC.
ARCHITECT	ENTECH ENGINEERING, INC.

<b>A S P Services Inc</b>		
Selinsgrove, PA 17870		
(570) 374-5333 FAX (570) 374-5335 <a href="http://aspservicesinc.co">aspservicesinc.co</a>		
DESCRIPTION	DATE	JOB No.
CHANNEL	11/03/2009	17-052-9
	DRAWN BY	DRG No.
TMAC		C18

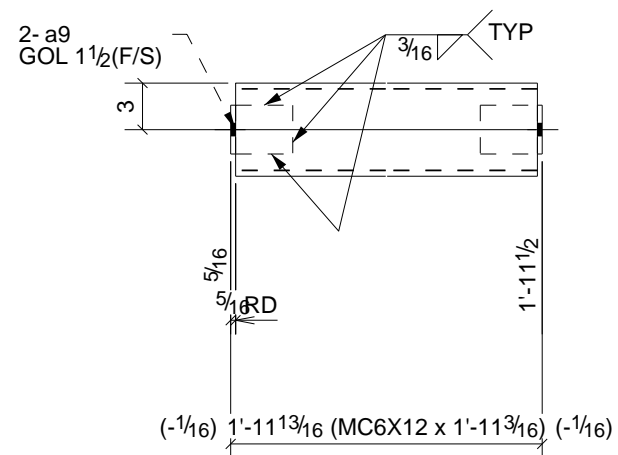

**ONE - BEAM - C19**

10/22/09	△	For Approval w/ Customer Field Data	TMAC
10/30/09	△	For Fabrication w/ Approver Comments	MT
DATE	NO.	DESCRIPTION	BY

**BILL OF MATERIAL**

Qty Ea.	Qty Tot	Piece Mark	Description	Length	Weight Total	Remarks	Adv Mill #	Steel Grade	STEEl ASTM	UNO	PROJECT NAME	A S P Services Inc Selinsgrove, PA 17870 (570) 374-5333 FAX (570) 374-5335 aspsservicesinc.com				
	1	C19	BEAM								LITITZ W.W.T.P.	CONTRACTOR <b>PLEASANT MOUNT WELDING, INC.</b>  ARCHITECT <b>ENTECH ENGINEERING, INC.</b>	DESCRIPTION		DATE	JOB No.
	1		MC6X12	1'-11 3/16"	23	SQ-2		A36	ELECTRODES	UNO	WARWICK TWP.-LANCASTER CO., PA		CHANNEL ASS'Y		10/22/2009	17-052-9
	2	a9	L4X3X5/16	0'-3 1/8"	4			A36	WELDS	UNO			DRAWN BY		TMAC	DRG No.
									OPEN HOLES	UNO						C19
									BOLTS	UNO						
									PAINT	UNO						
										UNO						

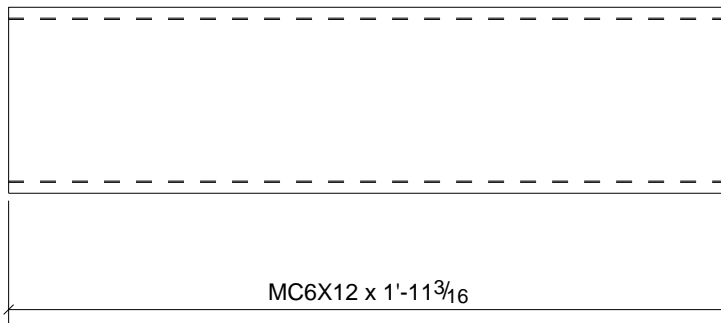

1	C19
Qty.	In Assembly

Qty.	Mark	Size	Length	Comments	Grade
1	C19	MC6X12	1'-11 3/16"		A36

PROJECT NAME	LITITZ W.W.T.P.
LOCATION	WARWICK TWP.-LANCASTER CO., PA
CUSTOMER	PLEASANT MOUNT WELDING, INC.
ARCHITECT	ENTECH ENGINEERING, INC.

<b>A S P Services Inc</b>		
Selinsgrove, PA 17870		
(570) 374-5333 FAX (570) 374-5335 <a href="http://aspservicesinc.co">aspservicesinc.co</a>		
DESCRIPTION	DATE	JOB No.
CHANNEL	11/03/2009	17-052-9
	DRAWN BY	DRG No.
TMAC		C19

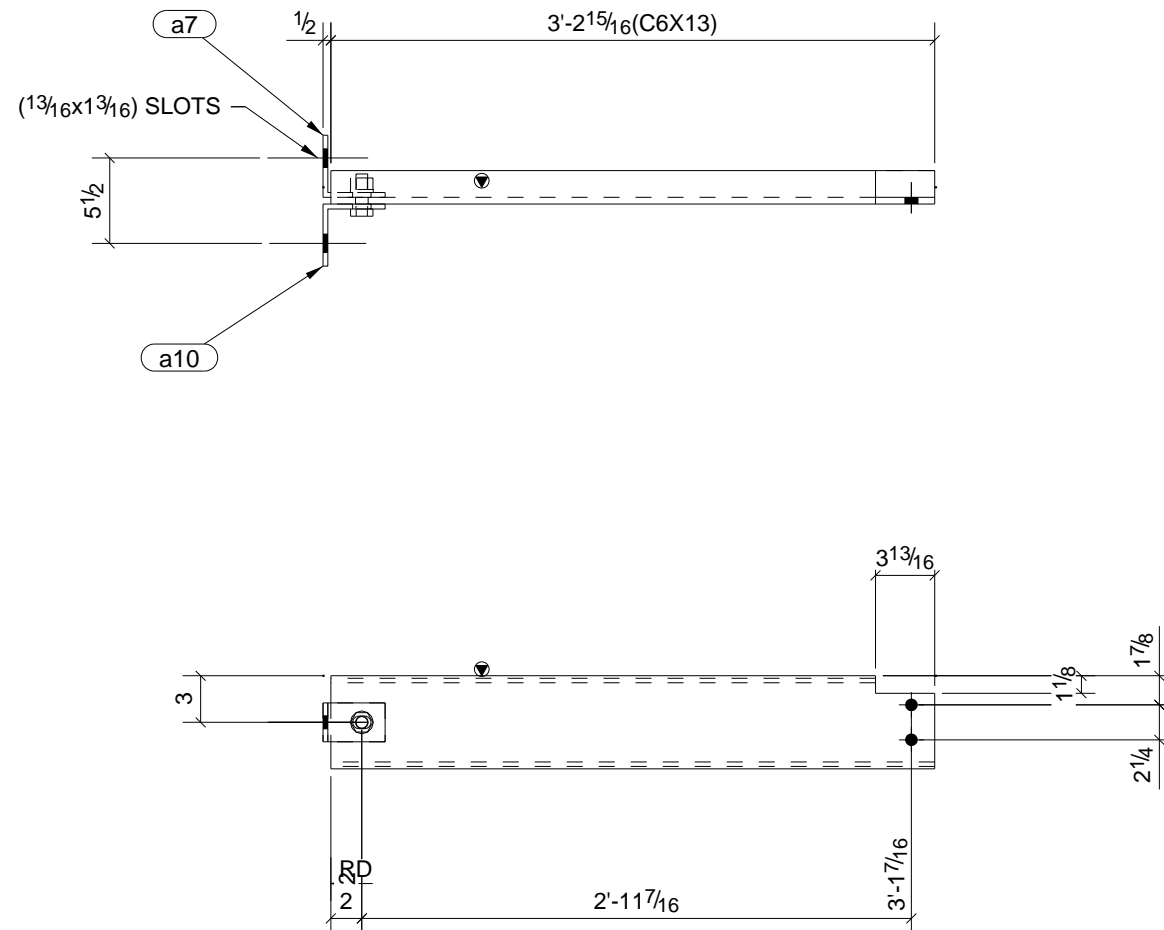

### 4 - BEAMS - C4

### BILL OF MATERIAL

Qty Ea.	Qty Tot	Piece Mark	Description	Length	Weight Total	Remarks	Adv Mill #	Steel Grade
	4	C4	BEAMS					
4	4		C6X13	3'-2 15/16"	168	SQ-2		A36
1	4	a7	L4X4X5/16	0'-2 1/2"	7			A36
1	4	a10	L4X4X5/16	0'-2 1/2"	7			A36
1	4		3/4"Ø A325N BOLT	0'-2 1/4"	2			

STEEL ASTM	A992	UNO	PROJECT NAME	LITITZ W.W.T.P.
ELECTRODES	E70xx LH	UNO	LOCATION	WARWICK TWP.-LANCASTER CO., PA
WELDS	1/4 BUTT/FILLET	UNO	CONTRACTOR	PLEASANT MOUNT WELDING, INC.
OPEN HOLES	13/16"	UNO	ARCHITECT	ENTECH ENGINEERING, INC.
BOLTS	3/4"Ø A325-N-ST	UNO		
PAINT	PER SPECS	UNO		

10/22/09	△C	For Approval w/ Customer Field Data	TMAC
6/04/09	△B	For Approval	TMAC
5/12/09	△A	For Approval	TMAC
10/30/09	△0	For Fabrication w/ Approver Comments	MT
DATE	NO.	DESCRIPTION	BY

<b>A S P Services Inc</b> Selinsgrove, PA 17870 (570) 374-5333 FAX (570) 374-5335 asp-services-inc.com			
DESCRIPTION	DATE	JOB No.	
CHANNEL ASS'Y	10/21/2009	17-052-9	
	DRAWN BY	DRG No.	
	TMAC	C4	

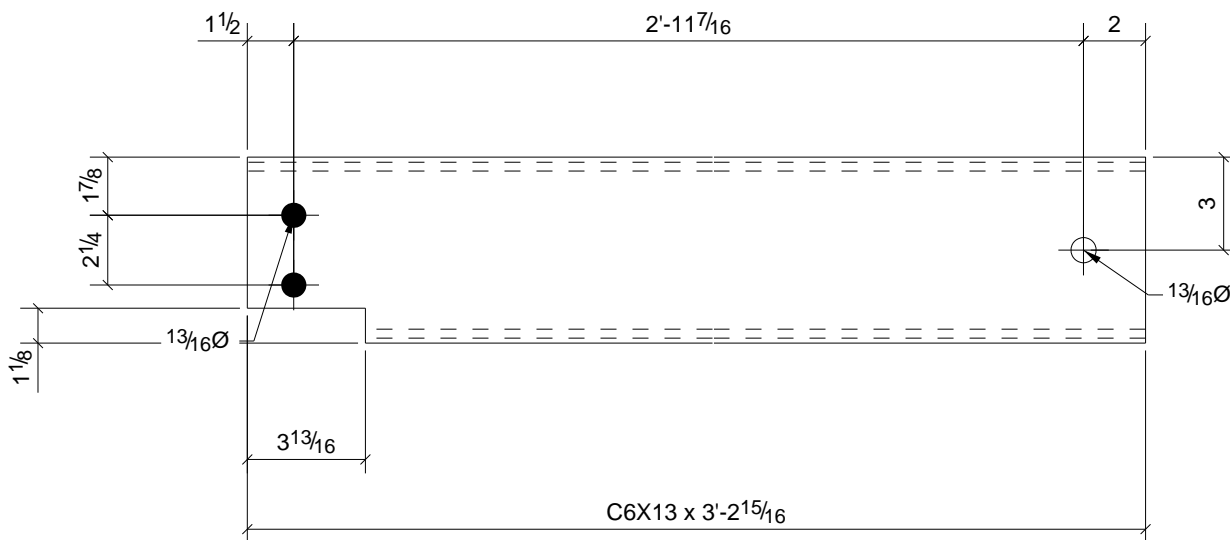

4	C4
Qty.	In Assembly

4	C4	C6X13	3'-2 15/16"		A36
Qty.	Mark	Size	Length	Comments	Grade

PROJECT NAME	LITITZ W.W.T.P.
LOCATION	WARWICK TWP.-LANCASTER CO., PA
CUSTOMER	PLEASANT MOUNT WELDING, INC.
ARCHITECT	ENTECH ENGINEERING, INC.

<b>A S P Services Inc</b>	
Selinsgrove, PA 17870	
(570) 374-5333 FAX (570) 374-5335 asp-servicesinc.co	
DESCRIPTION	CHANNEL
DATE	10/21/2009
JOB No.	17-052-9
DRAWN BY	TMAC
DRG No.	C4

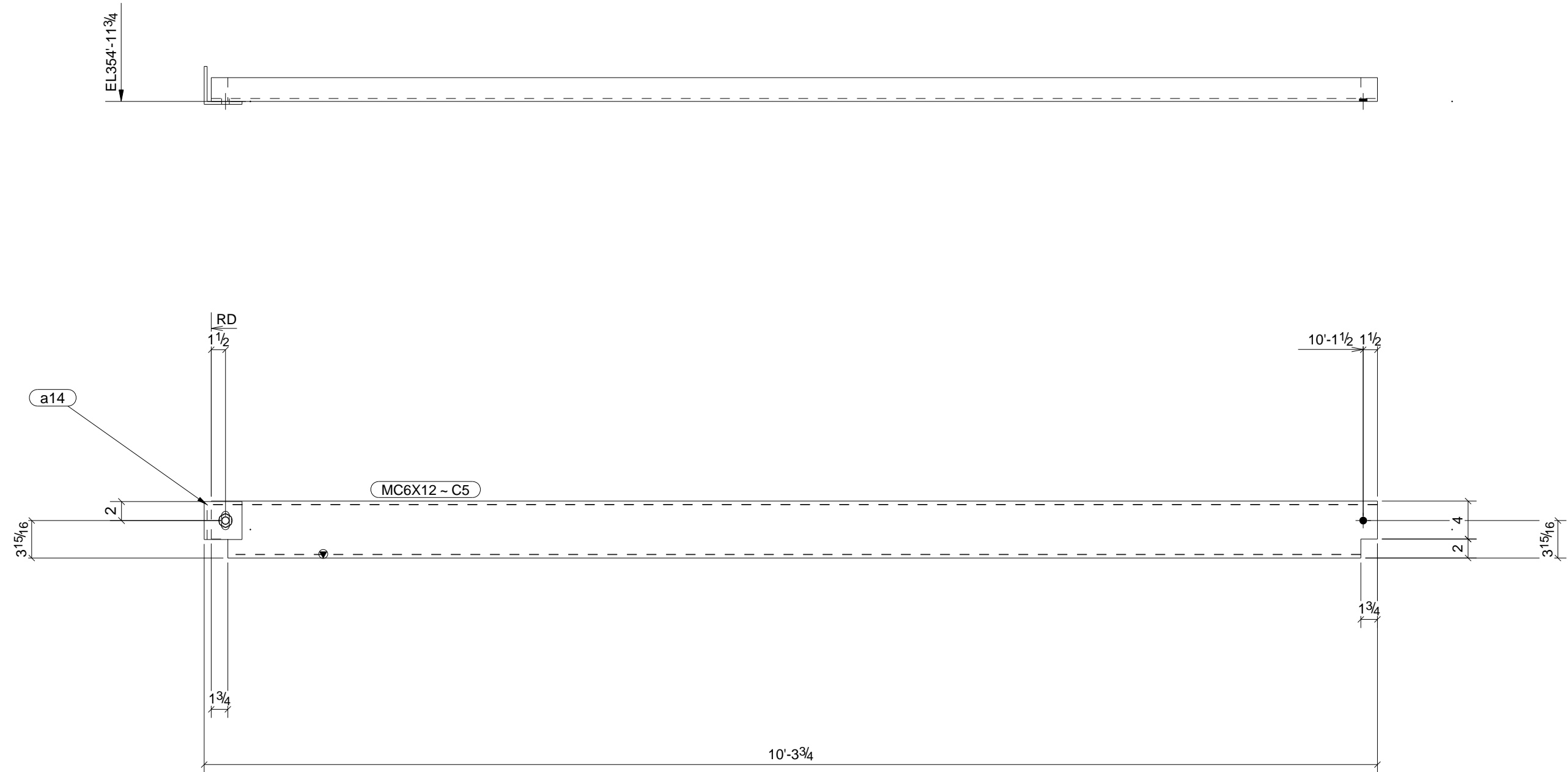

**ONE - BEAM - C5**

**BILL OF MATERIAL**

Qty Ea.	Qty Tot	Piece Mark	Description	Length	Weight Total	Remarks	Adv Mill #	Steel Grade
	1	C5	BEAM					
1	1		MC6X12	10'-3"	123	SQ-2		A36
1	1	a14	L4X4X5/16	0'-4"	3			A36
1	1		3/4"Ø A325N BOLT	0'-1 3/4"	1			

STEEL ASTM	A992	UNO
ELECTRODES	E70xx LH	UNO
WELDS	1/4 BUTT/FILLET	UNO
OPEN HOLES	13/16"	UNO
BOLTS	3/4"Ø A325-N-ST	UNO
PAINT	PER SPECS	UNO

PROJECT NAME	LITITZ W.W.T.P.
LOCATION	WARWICK TWP.-LANCASTER CO., PA
CONTRACTOR	PLEASANT MOUNT WELDING, INC.
ARCHITECT	ENTECH ENGINEERING, INC.

10/22/09	△C	For Approval w/ Customer FieldData	TMAC
6/04/09	△B	For Approval	TMAC
5/12/09	△A	For Approval	TMAC
10/30/09	△0	For Fabrication w/ Approver Comments	MT
DATE	NO.	DESCRIPTION	BY

<b>A S P Services Inc</b> Selinsgrove, PA 17870 (570) 374-5333 FAX (570) 374-5335 aspservicesinc.com		
DESCRIPTION	DATE	JOB No.
CHANNEL ASS'Y	11/03/2009	17-052-9
	DRAWN BY	DRG No.
	TMAC	C5

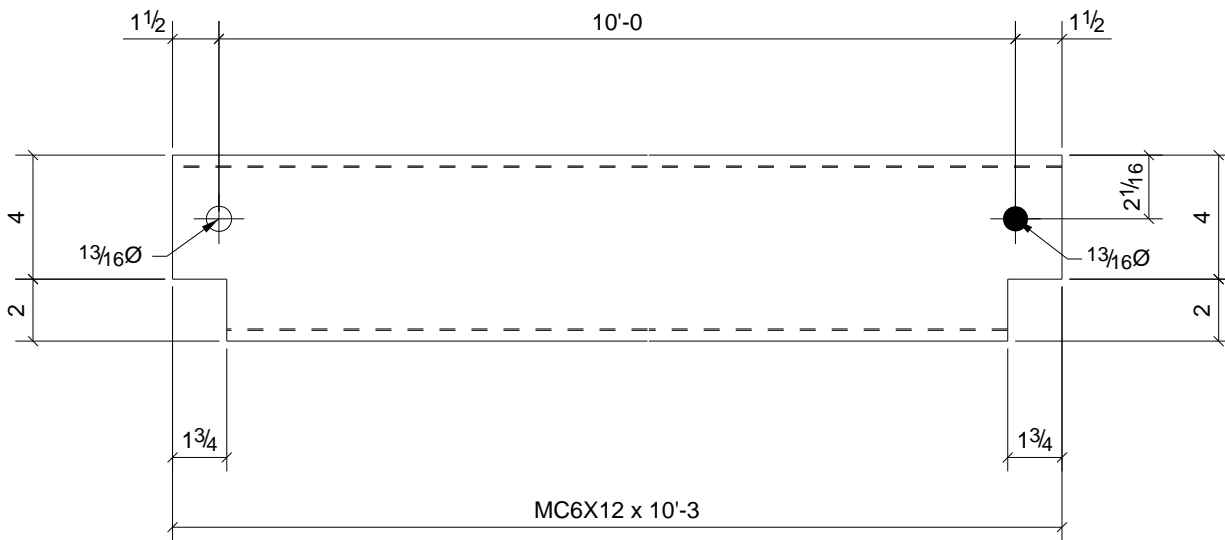

1	C5
Qty.	In Assembly

1	C5	MC6X12	10'-3"		A36
Qty.	Mark	Size	Length	Comments	Grade

PROJECT NAME	LITITZ W.W.T.P.
LOCATION	WARWICK TWP.-LANCASTER CO., PA
CUSTOMER	PLEASANT MOUNT WELDING, INC.
ARCHITECT	ENTECH ENGINEERING, INC.

<b>A S P Services Inc</b>	
Selinsgrove, PA 17870 (570) 374-5333 FAX (570) 374-5335 <a href="http://aspservicesinc.co">aspservicesinc.co</a>	
DESCRIPTION	CHANNEL
DATE	11/03/2009
JOB No.	17-052-9
DRAWN BY	
DRG No.	C5

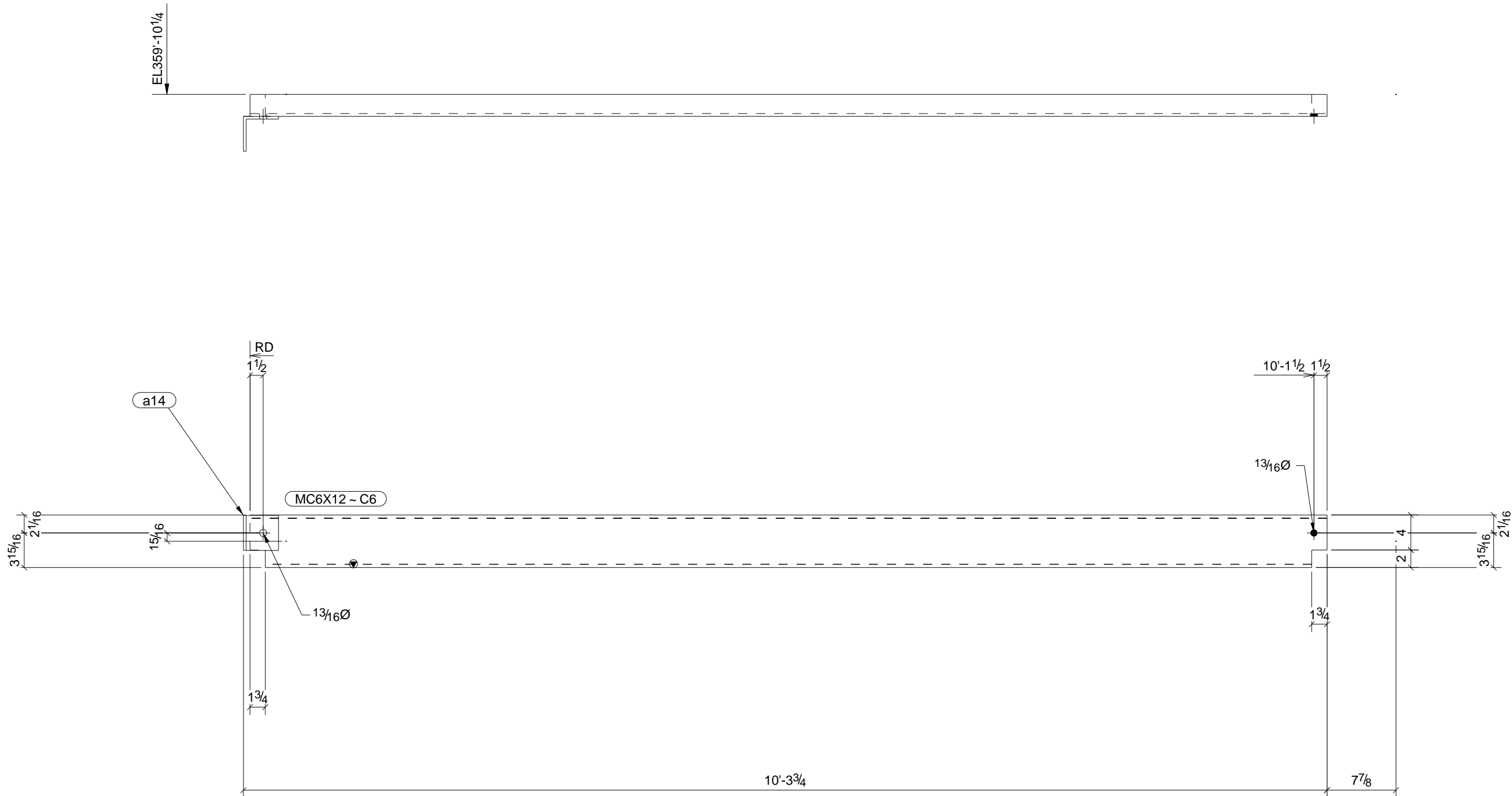

**ONE - BEAM - C6**

**BILL OF MATERIAL**

Qty Ea.	Qty Tot	Piece Mark	Description	Length	Weight Total	Remarks	Adv Mill #	Steel Grade
	1	C6	BEAM					
1	1		MC6X12	10'-3"	123	SQ-2		A36
1	1	a14	L4X4X5/16	0'-4"	3			A36
1	1		3/4"Ø A325N BOLT	0'-1 3/4"	1			

  

STEEL ASTM	A992	UNO	PROJECT NAME	LITITZ W.W.T.P.
ELECTRODES	E70xx LH	UNO	LOCATION	WARWICK TWP.-LANCASTER CO., PA
WELDS	1/4 BUTT/FILLET	UNO	CONTRACTOR	PLEASANT MOUNT WELDING, INC.
OPEN HOLES	13/16"	UNO	ARCHITECT	ENTECH ENGINEERING, INC.
BOLTS	3/4"Ø A325-N-ST	UNO		
PAINT	PER SPECS	UNO		

DATE	NO.	DESCRIPTION	BY
		<b>A S P Services Inc</b> Selinsgrove, PA 17870 (570) 374-5333 FAX (570) 374-5335 aspsservicesinc.com	
		DESCRIPTION	CHANNEL ASS'Y
		DATE	11/03/2009
		DRAWN BY	TMAC
		JOB No.	17-052-9
		DRG No.	C6



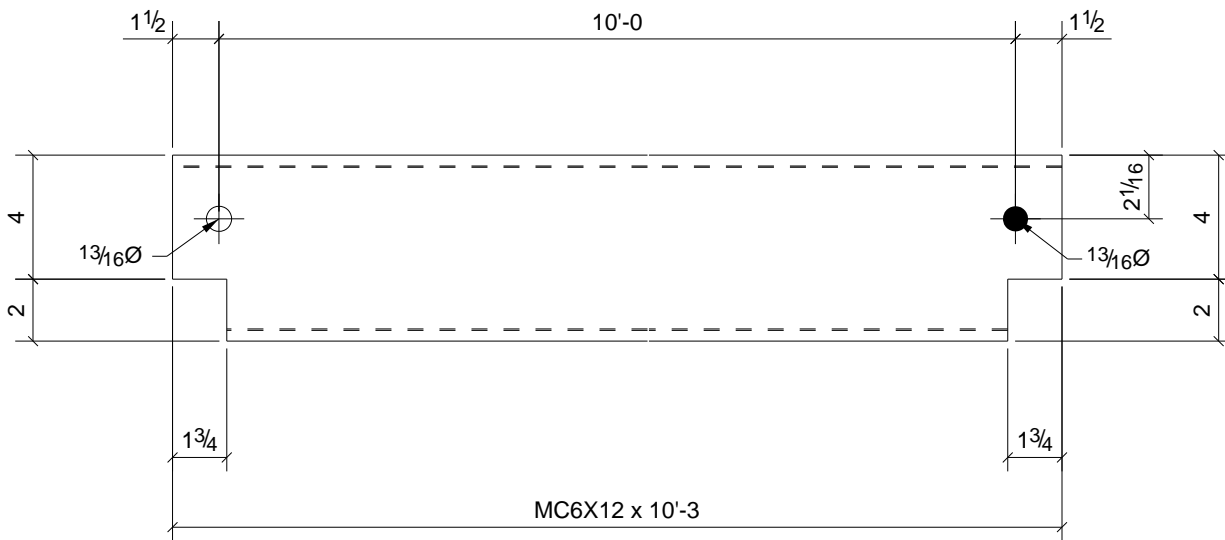

1	C6
Qty.	In Assembly

Qty.	Mark	Size	Length	Comments	Grade
1	C6	MC6X12	10'-3"		A36

PROJECT NAME	LITITZ W.W.T.P.
LOCATION	WARWICK TWP.-LANCASTER CO., PA
CUSTOMER	PLEASANT MOUNT WELDING, INC.
ARCHITECT	ENTECH ENGINEERING, INC.

<b>A S P Services Inc</b>	
Selinsgrove, PA 17870 (570) 374-5333 FAX (570) 374-5335 <a href="http://aspservicesinc.co">aspservicesinc.co</a>	
DESCRIPTION	CHANNEL
DATE	11/03/2009
JOB No.	17-052-9
DRAWN BY	
DRG No.	C6

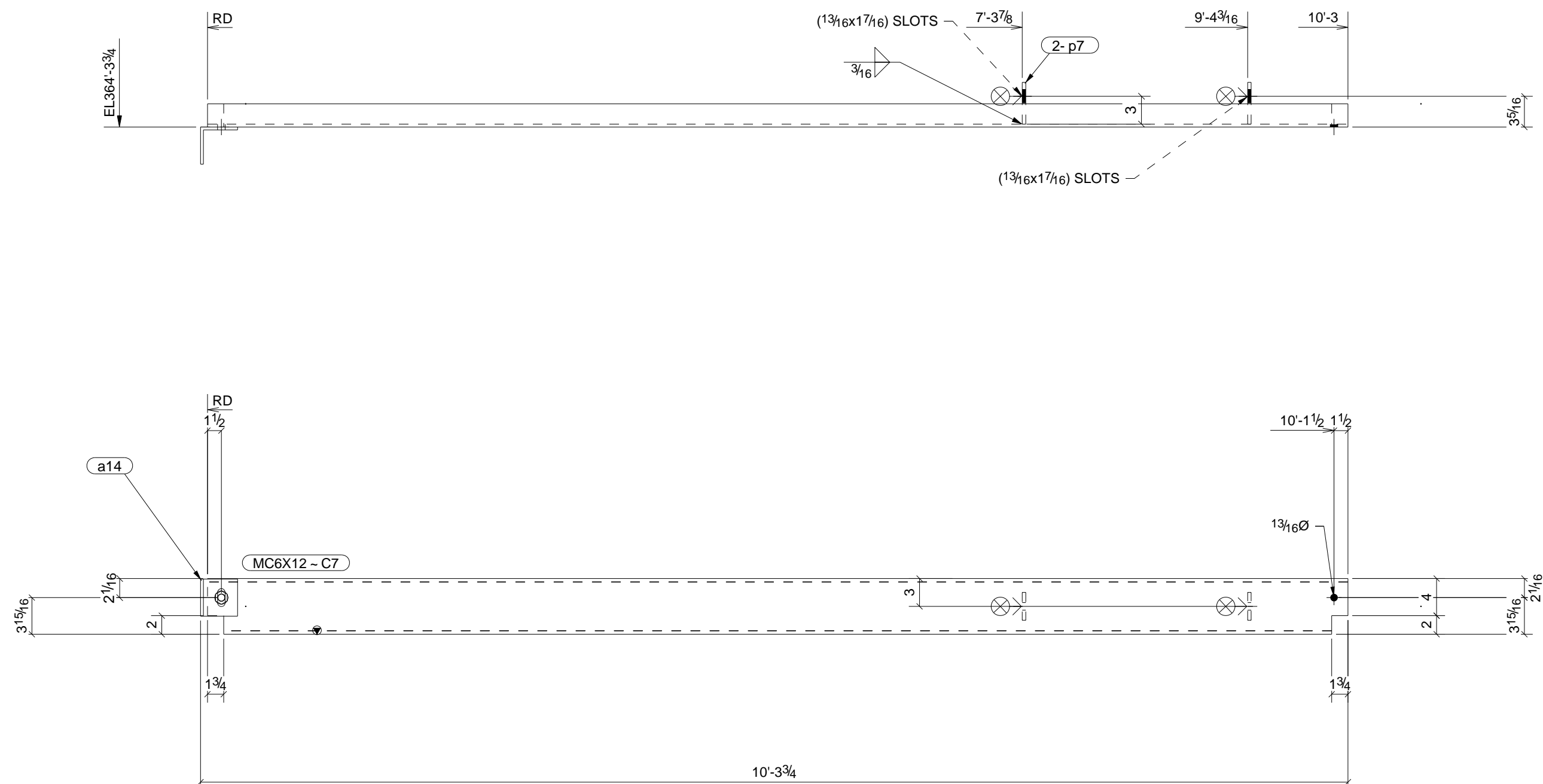

**ONE - BEAM - C7**

**BILL OF MATERIAL**

Qty Ea.	Qty Tot	Piece Mark	Description	Length	Weight Total	Remarks	Adv Mill #	Steel Grade
	1	C7	BEAM					
1	1		MC6X12	10'-3"	123	SQ-2		A36
1	1	a14	L4X4X5/16	0'-4"	3			A36
2	2	p7	FL3/8"X3"	0'-4 1/2"	3			A36
1	1		3/4"Ø A325N BOLT	0'-1 3/4"	1			

STEEL ASTM	A992	UNO	PROJECT NAME	LITITZ W.W.T.P.
ELECTRODES	E70xx LH	UNO	LOCATION	WARWICK TWP.-LANCASTER CO., PA
WELDS	1/4 BUTT/FILLET	UNO	CONTRACTOR	PLEASANT MOUNT WELDING, INC.
OPEN HOLES	13/16"	UNO	ARCHITECT	ENTECH ENGINEERING, INC.
BOLTS	3/4"Ø A325-N-ST	UNO		
PAINT	PER SPECS	UNO		

10/22/09	△C	For Approval w/ Customer FieldData	TMAC
6/04/09	△B	For Approval	TMAC
5/12/09	△A	For Approval	TMAC
10/30/09	△D	For Fabrication w/ Approver Comments	MT
DATE	NO.	DESCRIPTION	BY

**A S P Services Inc**  
 Selinsgrove, PA 17870  
 (570) 374-5333 FAX (570) 374-5335 aspsservicesinc.com

DESCRIPTION	DATE	JOB No.
CHANNEL ASS'Y	11/03/2009	17-052-9
	DRAWN BY	DRG No.
	TMAC	C7

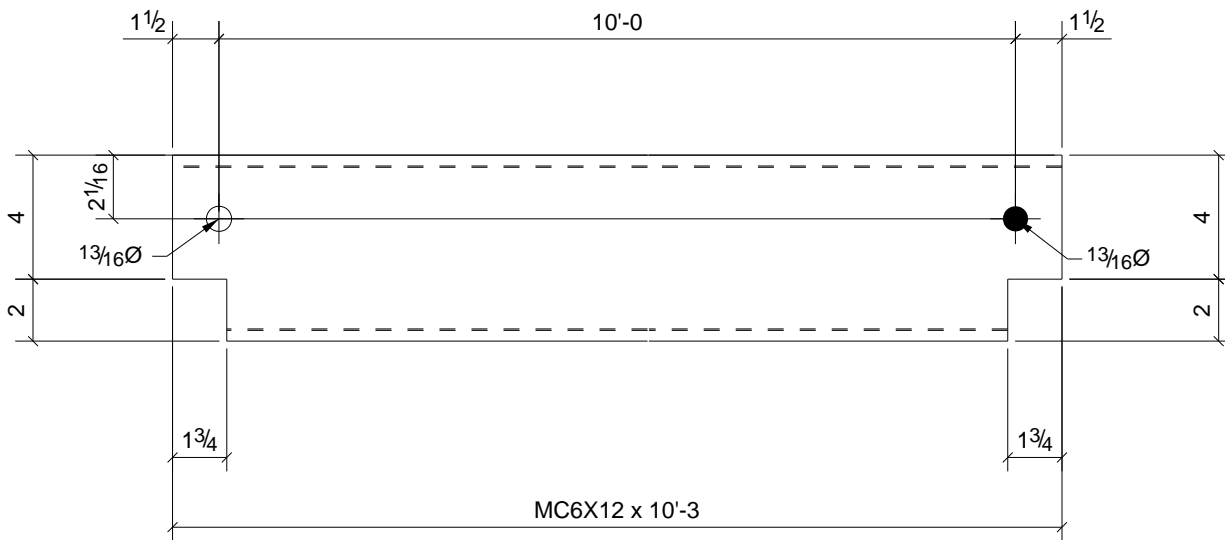

1	C7
Qty.	In Assembly

1	C7	MC6X12	10'-3"		A36
Qty.	Mark	Size	Length	Comments	Grade

PROJECT NAME	LITITZ W.W.T.P.
LOCATION	WARWICK TWP.-LANCASTER CO., PA
CUSTOMER	PLEASANT MOUNT WELDING, INC.
ARCHITECT	ENTECH ENGINEERING, INC.

<b>A S P Services Inc</b>	
Selinsgrove, PA 17870	
(570) 374-5333 FAX (570) 374-5335 <a href="http://aspservicesinc.co">aspservicesinc.co</a>	
DESCRIPTION	CHANNEL
DATE	11/03/2009
JOB No.	17-052-9
DRAWN BY	
DRG No.	C7

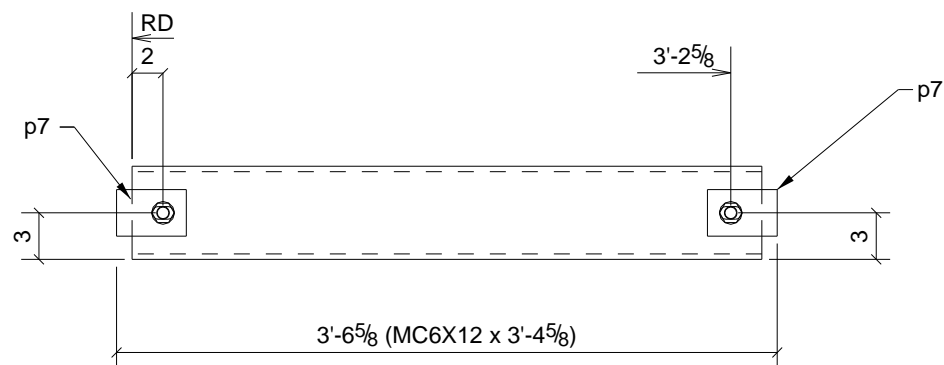

**2 - CHANNELS - C8**

10/22/09	△C	For Approval w/ Customer Field Data	TMAC
6/04/09	△B	For Approval	TMAC
5/12/09	△A	For Approval	TMAC
10/30/09	△O	For Fabrication w/ Approver Comments	MT
DATE	NO.	DESCRIPTION	BY

**BILL OF MATERIAL**

Qty Ea.	Qty Tot	Piece Mark	Description	Length	Weight Total	Remarks	Adv Mill #	Steel Grade
	2	C8	CHANNELS					
2	2		MC6X12	3'-4 5/8"	81	SQ-2		A992
2	4	p7	FL3/8" X3"	0'-4 1/2"	6			A36
2	4		3/4"Ø A325N BOLT	0'-2"	2			

STEEL ASTM	A992	UNO	PROJECT NAME	LITITZ W.W.T.P.
ELECTRODES	E70xx LH	UNO	LOCATION	WARWICK TWP.-LANCASTER CO., PA
WELDS	1/4 BUTT/FILLET	UNO	CONTRACTOR	PLEASANT MOUNT WELDING, INC.
OPEN HOLES	13/16"	UNO	ARCHITECT	ENTECH ENGINEERING, INC.
BOLTS	3/4"Ø A325-N-ST	UNO		
PAINT	PER SPECS	UNO		

<b>A S P Services Inc</b>		
Selinsgrove, PA 17870		
(570) 374-5333 FAX (570) 374-5335 aspervicesinc.com		
DESCRIPTION	DATE	JOB No.
CHANNEL ASS'Y	10/21/2009	17-052-9
	DRAWN BY	DRG No.
	TMAC	C8

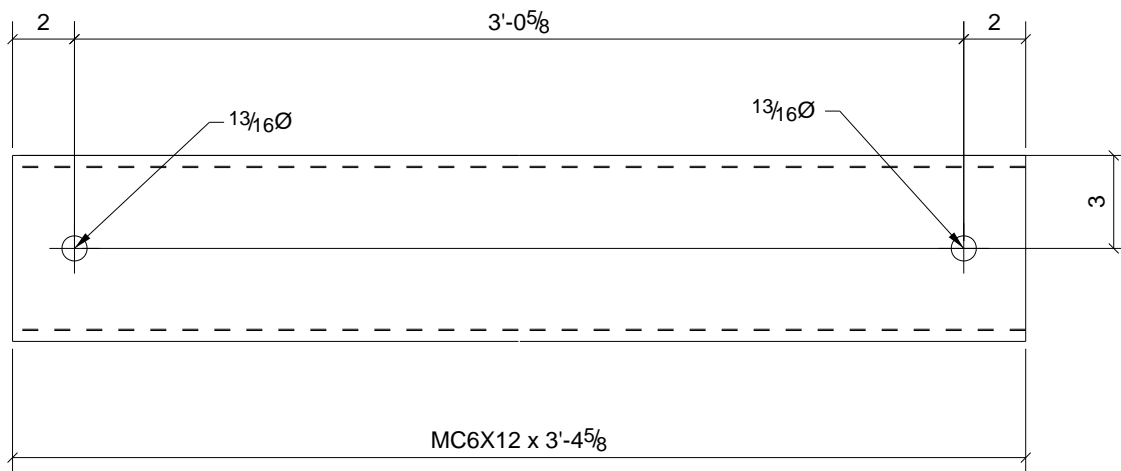

2	C8
Qty.	In Assembly

Qty.	Mark	Size	Length	Comments	Grade
2	C8	MC6X12	3'-4 5/8"		A992

PROJECT NAME	LITITZ W.W.T.P.
LOCATION	WARWICK TWP.-LANCASTER CO., PA
CUSTOMER	PLEASANT MOUNT WELDING, INC.
ARCHITECT	ENTECH ENGINEERING, INC.

<b>A S P Services Inc</b>		
Selinsgrove, PA 17870		
(570) 374-5333 FAX (570) 374-5335 <a href="http://aspservicesinc.co">aspservicesinc.co</a>		
DESCRIPTION	DATE	JOB No.
CHANNEL	10/21/2009	17-052-9
	DRAWN BY	DRG No.
TMAC		C8

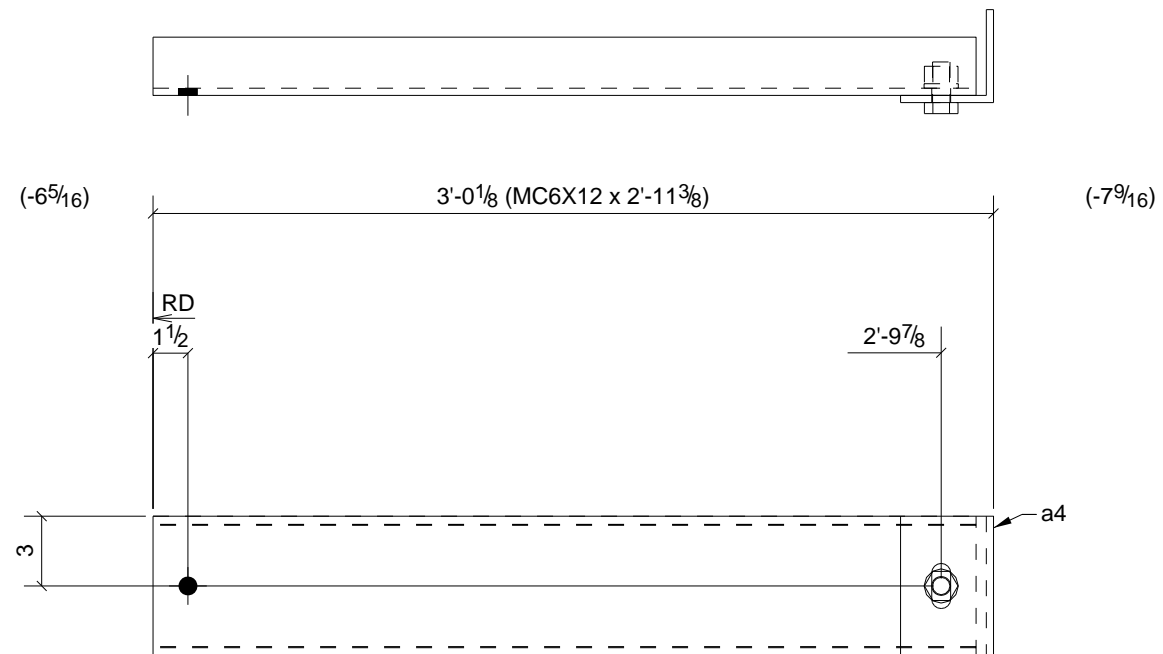

**ONE - BEAM - C9**

10/22/09	△C	For Approval w/ Customer FieldData	TMAC
6/04/09	△B	For Approval	TMAC
5/12/09	△A	For Approval	TMAC
10/30/09	△0	For Fabrication w/ Approver Comments	MT
DATE	NO.	DESCRIPTION	BY

**BILL OF MATERIAL**

Qty Ea.	Qty Tot	Piece Mark	Description	Length	Weight Total	Remarks	Adv Mill #	Steel Grade
	1	C9	BEAM					
1	1		MC6X12	2'-11 3/8"	35	SQ-2		A36
1	1	a4	L4X4X5/16	0'-6"	4			A36

STEEL ASTM	A992	UNO	PROJECT NAME	LITITZ W.W.T.P.
ELECTRODES	E70xx LH	UNO	LOCATION	WARWICK TWP.-LANCASTER CO., PA
WELDS	1/4 BUTT/FILLET	UNO	CONTRACTOR	PLEASANT MOUNT WELDING, INC.
OPEN HOLES	13/16"	UNO	ARCHITECT	ENTECH ENGINEERING, INC.
BOLTS	3/4"Ø A325-N-ST	UNO		
PAINT	PER SPECS	UNO		

<b>A S P Services Inc</b> Selinsgrove, PA 17870 (570) 374-5333 FAX (570) 374-5335 aspsservicesinc.com	
DESCRIPTION	CHANNEL ASS'Y
DATE	11/02/2009
DRAWN BY	
JOB No.	17-052-9
DRG No.	C9

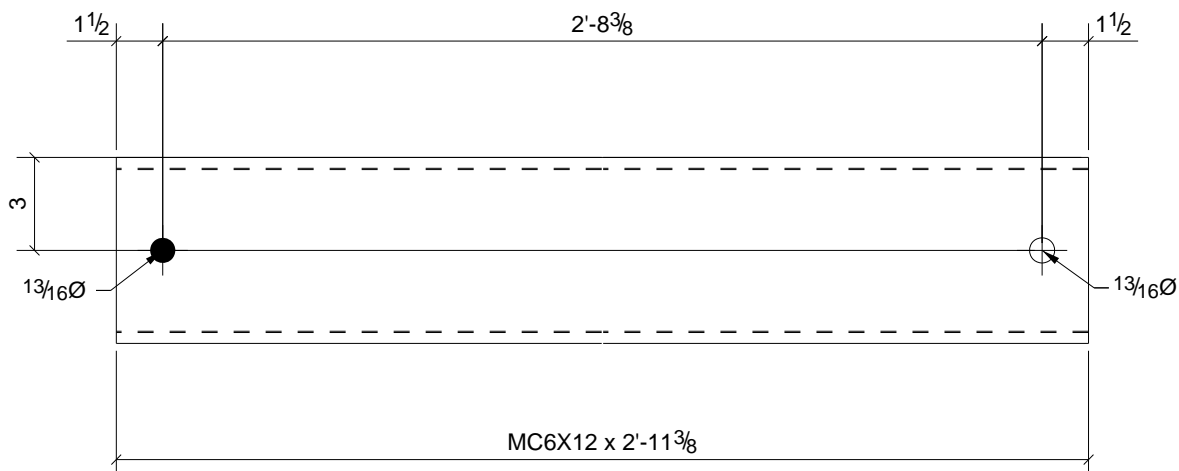

1	C9
Qty.	In Assembly

Qty.	Mark	Size	Length	Comments	Grade
1	C9	MC6X12	2'-11 3/8"		A36

PROJECT NAME	LITITZ W.W.T.P.
LOCATION	WARWICK TWP.-LANCASTER CO., PA
CUSTOMER	PLEASANT MOUNT WELDING, INC.
ARCHITECT	ENTECH ENGINEERING, INC.

<b>A S P Services Inc</b>		
Selinsgrove, PA 17870		
(570) 374-5333 FAX (570) 374-5335 asp-servicesinc.co		
DESCRIPTION	DATE	JOB No.
CHANNEL	11/03/2009	17-052-9
	DRAWN BY	DRG No.
TMAC		C9

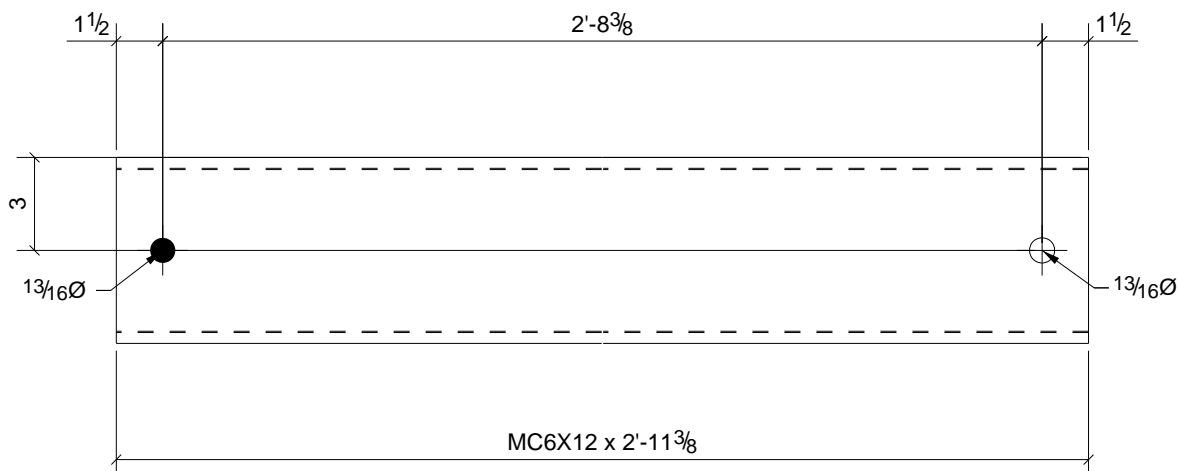

1	C9
Qty.	In Assembly

Qty.	Mark	Size	Length	Comments	Grade
1	C9	MC6X12	2'-11 3/8"		A36

PROJECT NAME	LITITZ W.W.T.P.
LOCATION	WARWICK TWP.-LANCASTER CO., PA
CUSTOMER	PLEASANT MOUNT WELDING, INC.
ARCHITECT	ENTECH ENGINEERING, INC.

<b>A S P Services Inc</b>		
Selinsgrove, PA 17870		
(570) 374-5333 FAX (570) 374-5335 asp-servicesinc.co		
DESCRIPTION	DATE	JOB No.
STANDARD	11/03/2009	17-052-9
	DRAWN BY	DRG No.
	TMAC	C9



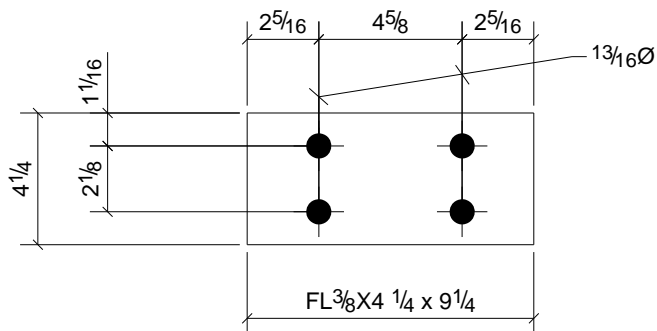

1	p1
Qty.	In Assembly

Qty.	Mark	Size	Length	Comments	Grade
1	p1	FL $\frac{3}{8}$ "X4 1/4"	0'-9 1/4"		A36

PROJECT NAME	LITITZ W.W.T.P.
LOCATION	WARWICK TWP.-LANCASTER CO., PA
CUSTOMER	PLEASANT MOUNT WELDING, INC.
ARCHITECT	ENTECH ENGINEERING, INC.

<b>A S P Services Inc</b>	
Selinsgrove, PA 17870	
(570) 374-5333 FAX (570) 374-5335 <a href="http://aspservicesinc.co">aspservicesinc.co</a>	
DESCRIPTION	PLATE
DATE	11/03/2009
JOB No.	17-052-9
DRAWN BY	
DRG No.	p1

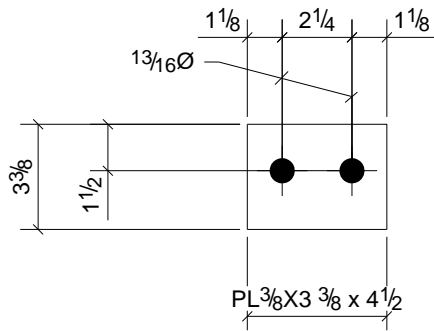

4	B7
Qty.	In Assembly

4	p5	PL $\frac{3}{8}$ "X $3\frac{3}{8}$ "	0'-4 1/2"		A36
Qty.	Mark	Size	Length	Comments	Grade

PROJECT NAME	LITITZ W.W.T.P.
LOCATION	WARWICK TWP.-LANCASTER CO., PA
CUSTOMER	PLEASANT MOUNT WELDING, INC.
ARCHITECT	ENTECH ENGINEERING, INC.

<b>A S P Services Inc</b>		
Selinsgrove, PA 17870		
(570) 374-5333 FAX (570) 374-5335 <a href="http://aspservicesinc.co">aspservicesinc.co</a>		
DESCRIPTION	DATE	JOB No.
PLATE	10/21/2009	17-052-9
	DRAWN BY	DRG No.
TMAC		p5

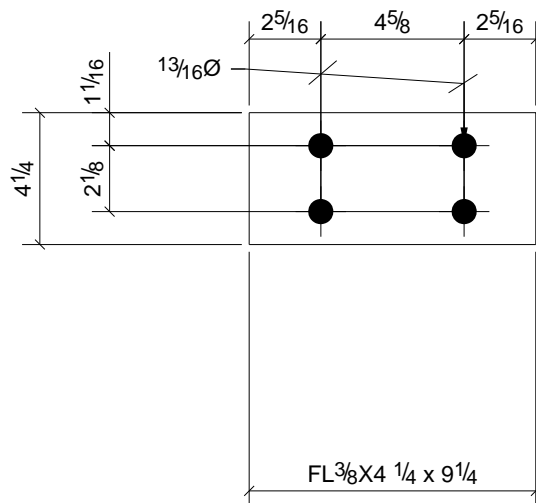

1	C14
Qty.	In Assembly

Qty.	Mark	Size	Length	Comments	Grade
1	p6	FL3/8"X4 1/4"	0'-9 1/4"		A36

PROJECT NAME	LITITZ W.W.T.P.
LOCATION	WARWICK TWP.-LANCASTER CO., PA
CUSTOMER	PLEASANT MOUNT WELDING, INC.
ARCHITECT	ENTECH ENGINEERING, INC.

<b>A S P Services Inc</b>	
Selinsgrove, PA 17870	
(570) 374-5333 FAX (570) 374-5335 <a href="http://aspservicesinc.co">aspservicesinc.co</a>	
DESCRIPTION	PLATE
DATE	11/03/2009
JOB No.	17-052-9
DRAWN BY	
DRG No.	p6

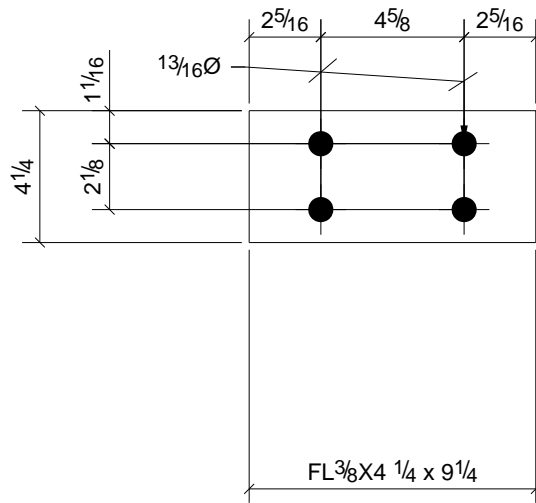

1	C14
Qty.	In Assembly

1	p6	FL3/8"X4 1/4"	0'-9 1/4"		A36
Qty.	Mark	Size	Length	Comments	Grade

PROJECT NAME	LITITZ W.W.T.P.
LOCATION	WARWICK TWP.-LANCASTER CO., PA
CUSTOMER	PLEASANT MOUNT WELDING, INC.
ARCHITECT	ENTECH ENGINEERING, INC.

<b>A S P Services Inc</b>	
Selinsgrove, PA 17870	
(570) 374-5333 FAX (570) 374-5335 <a href="http://aspservicesinc.co">aspservicesinc.co</a>	
DESCRIPTION	STANDARD
DATE	11/03/2009
JOB No.	17-052-9
DRAWN BY	
DRG No.	p6

(1<sup>3</sup>/<sub>16</sub>x1<sup>7</sup>/<sub>16</sub>) SLOTS

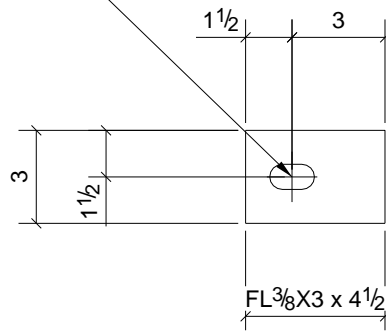

2	C7
4	C8
Qty.	In Assembly

6	p7	FL3/8"X3"	0'-4 1/2"		A36
Qty.	Mark	Size	Length	Comments	Grade

PROJECT NAME LITITZ W.W.T.P.		<b>A S P Services Inc</b> Selinsgrove, PA 17870 (570) 374-5333 FAX (570) 374-5335 asp-servicesinc.co			
LOCATION WARWICK TWP.-LANCASTER CO., PA					
CUSTOMER PLEASANT MOUNT WELDING, INC.		DESCRIPTION PLATE	DATE 06/03/2009	JOB No. 17-052-9	
ARCHITECT ENTECH ENGINEERING, INC.			DRAWN BY	DRG No. p7	

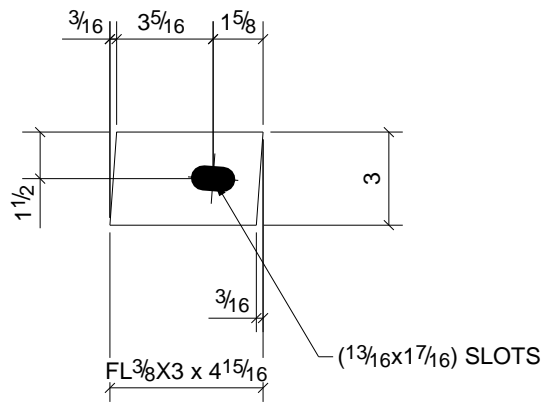

2	C17
Qty.	In Assembly

2	p8	FL 3/8" X 3"	0'-4 15/16"		A36
Qty.	Mark	Size	Length	Comments	Grade

PROJECT NAME	LITITZ W.W.T.P.
LOCATION	WARWICK TWP.-LANCASTER CO., PA
CUSTOMER	PLEASANT MOUNT WELDING, INC.
ARCHITECT	ENTECH ENGINEERING, INC.

<b>A S P Services Inc</b>	
Selinsgrove, PA 17870	
(570) 374-5333 FAX (570) 374-5335 <a href="http://aspservicesinc.co">aspservicesinc.co</a>	
DESCRIPTION	PLATE
DATE	06/03/2009
JOB No.	17-052-9
DRAWN BY	
DRG No.	p8

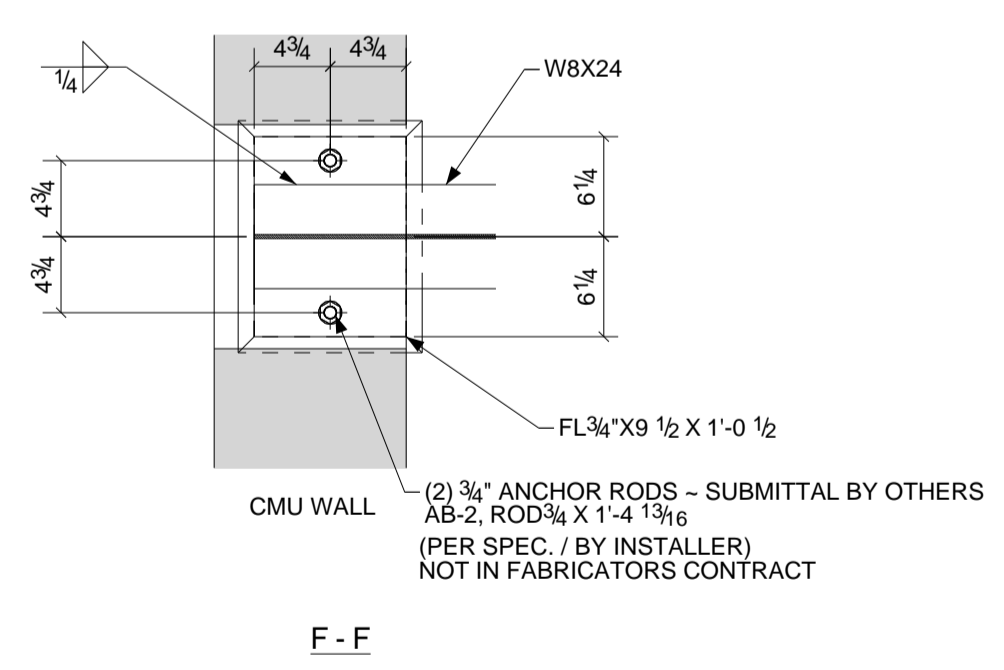
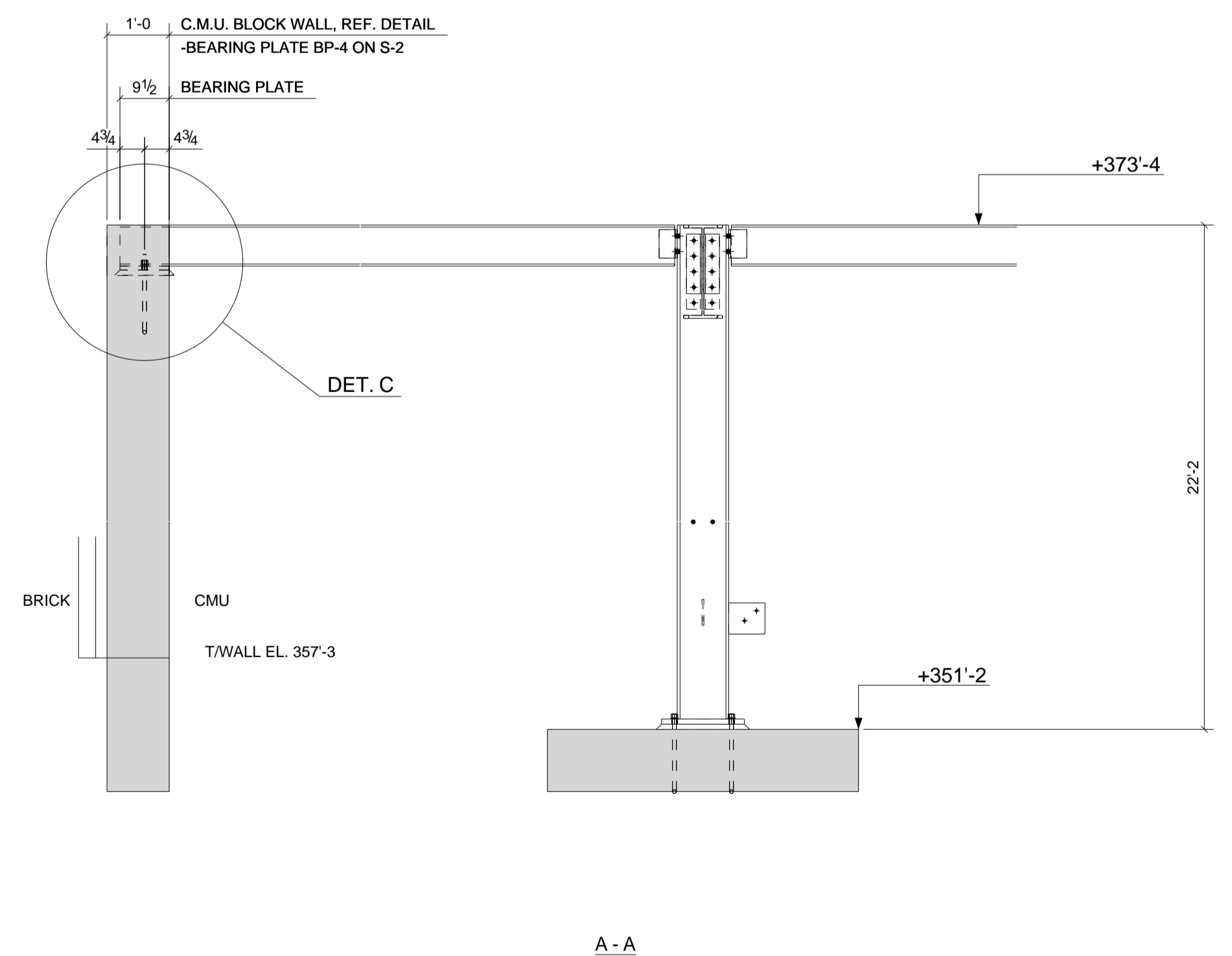
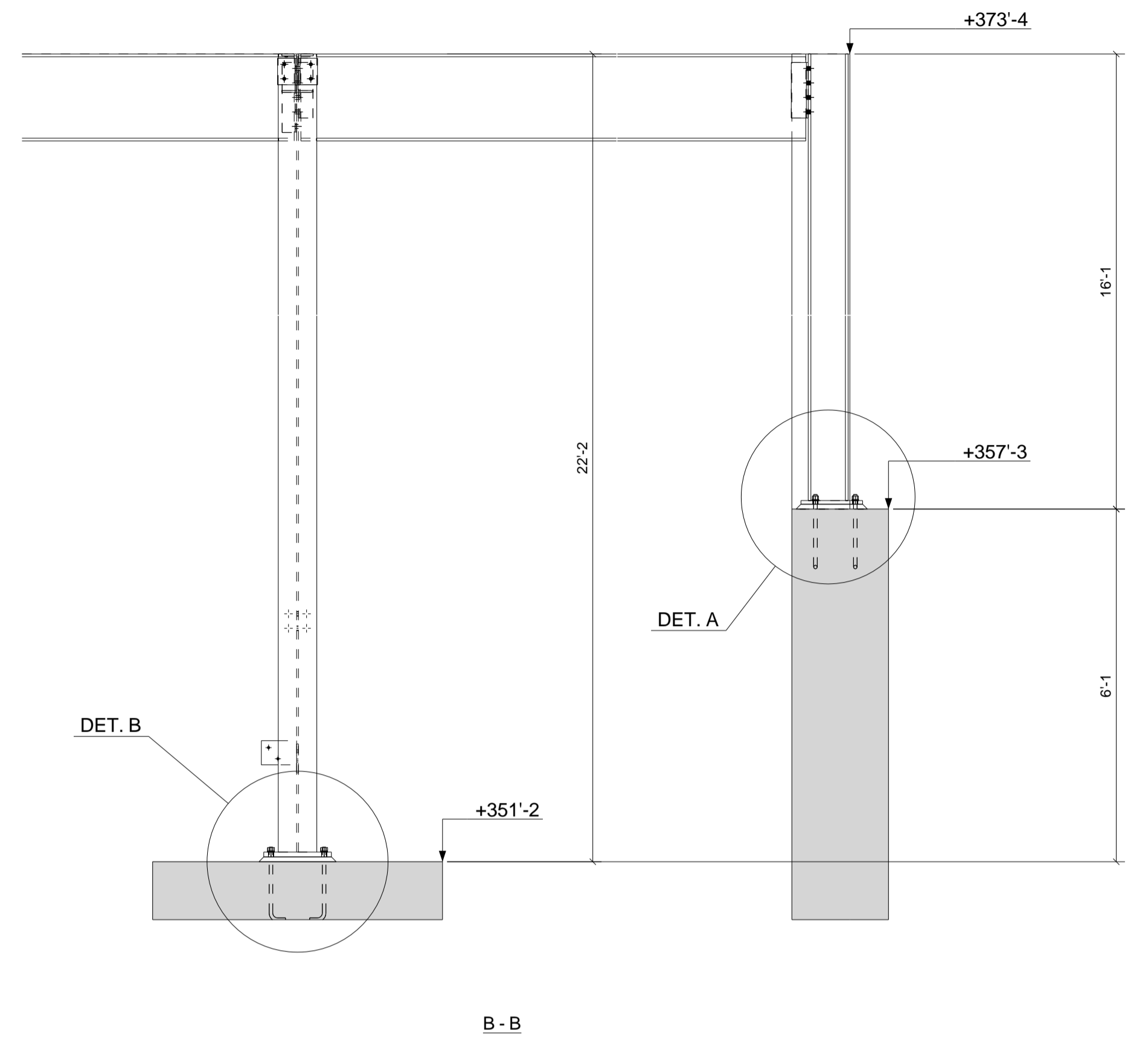
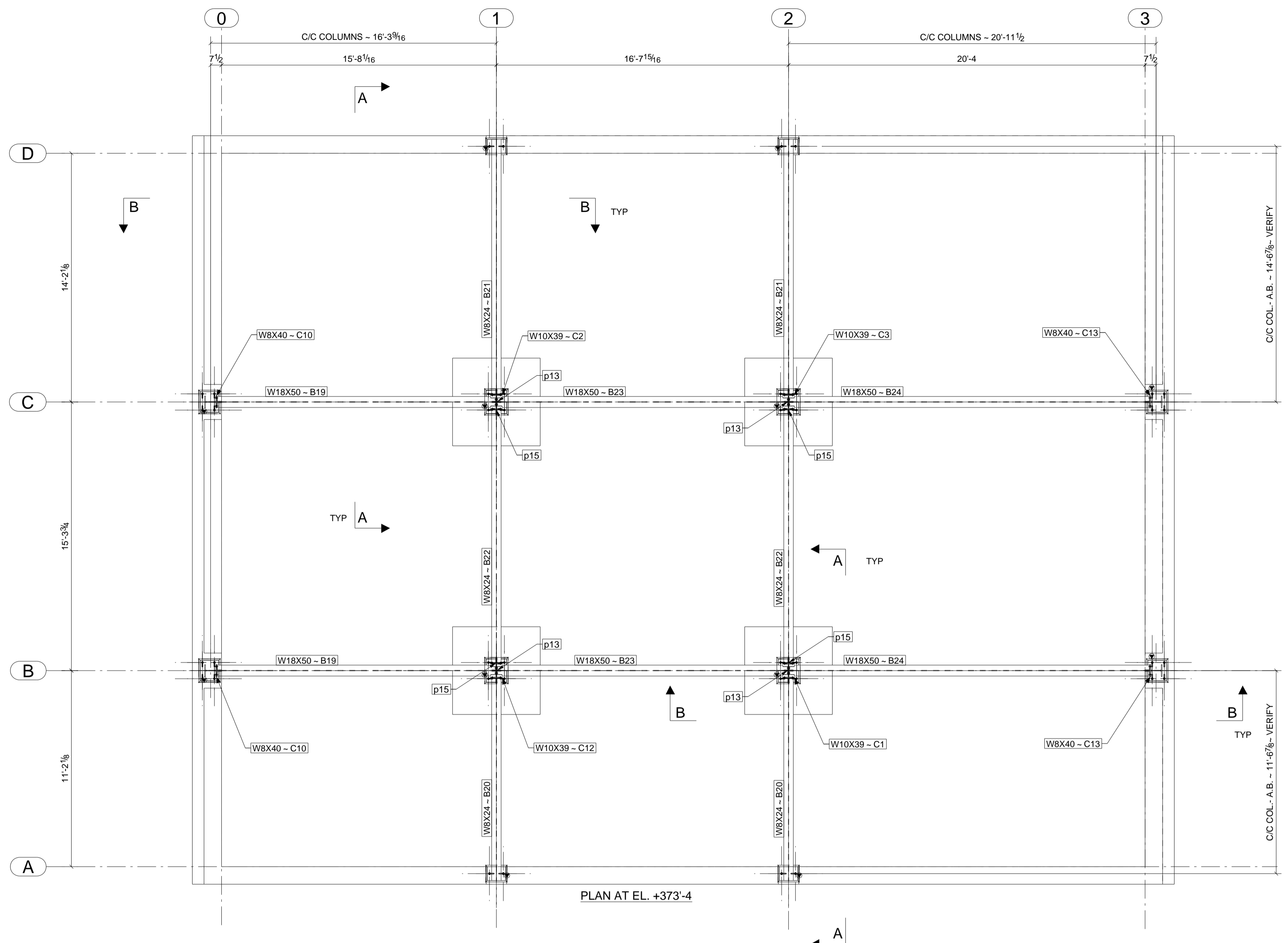

(2) 3/4" ANCHOR RODS - SUBMITTAL BY OTHERS  
 AB-2, ROD 3/4" X 1'-4" 13/16"  
 (PER SPEC. / BY INSTALLER)  
 NOT IN FABRICATORS CONTRACT

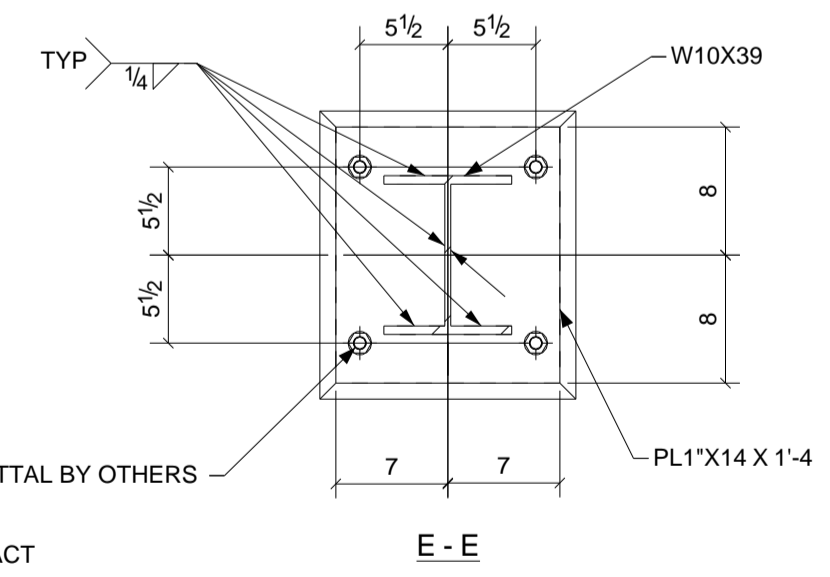

(2) 3/4" ANCHOR RODS - SUBMITTAL BY OTHERS  
 AB-2, ROD 3/4" X 1'-4" 13/16"  
 (PER SPEC. / BY INSTALLER)  
 NOT IN FABRICATORS CONTRACT

(4) 3/4" ANCHOR RODS - SUBMITTAL BY OTHERS  
 AB-1, ROD 3/4" X 1'-4" 13/16"  
 (PER SPEC. / BY INSTALLER)  
 NOT IN FABRICATORS CONTRACT

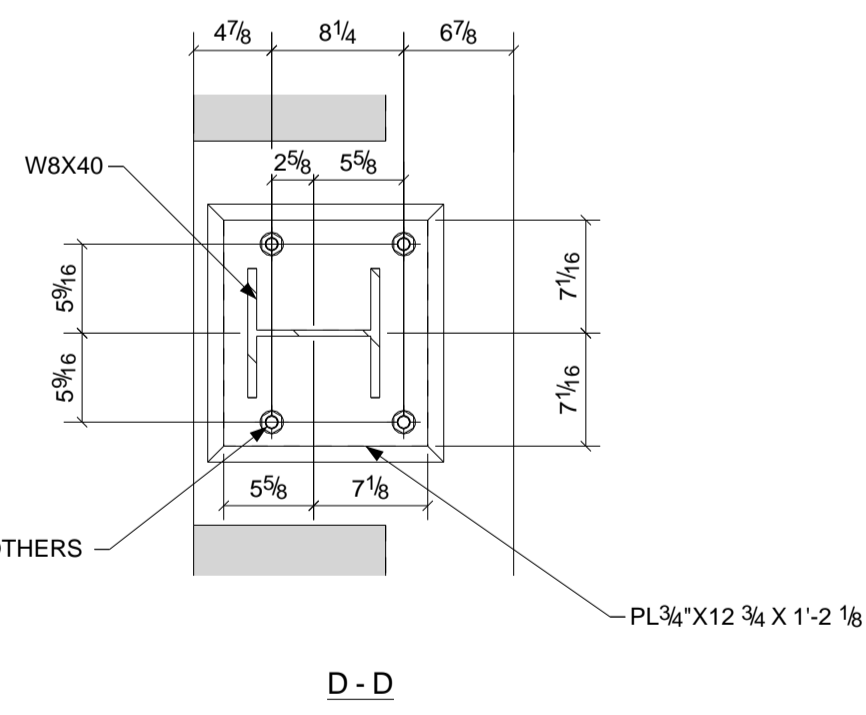

D - D

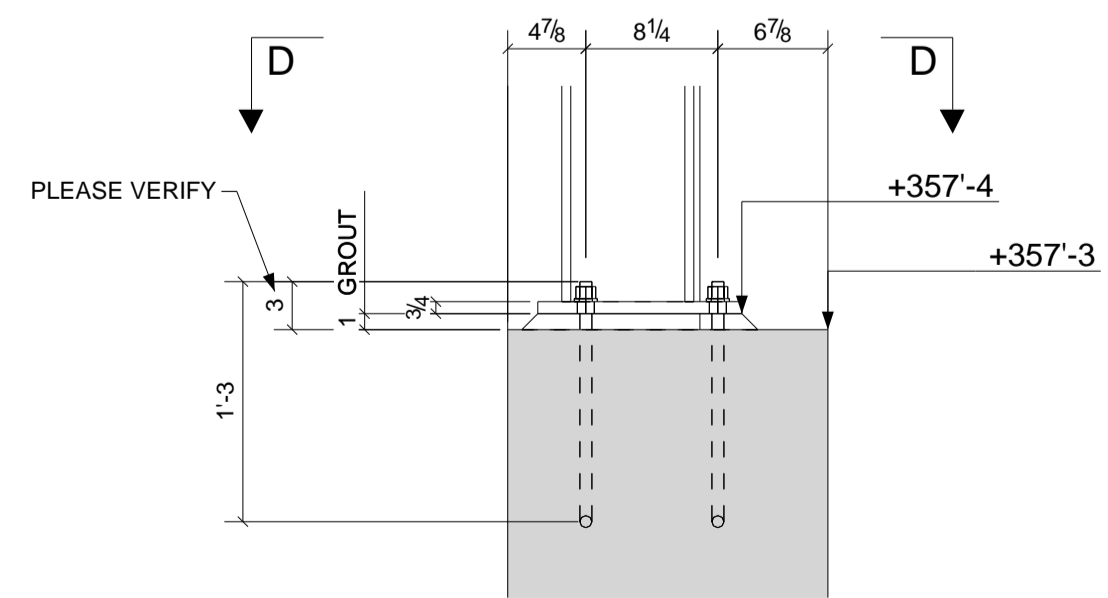

DETAIL A

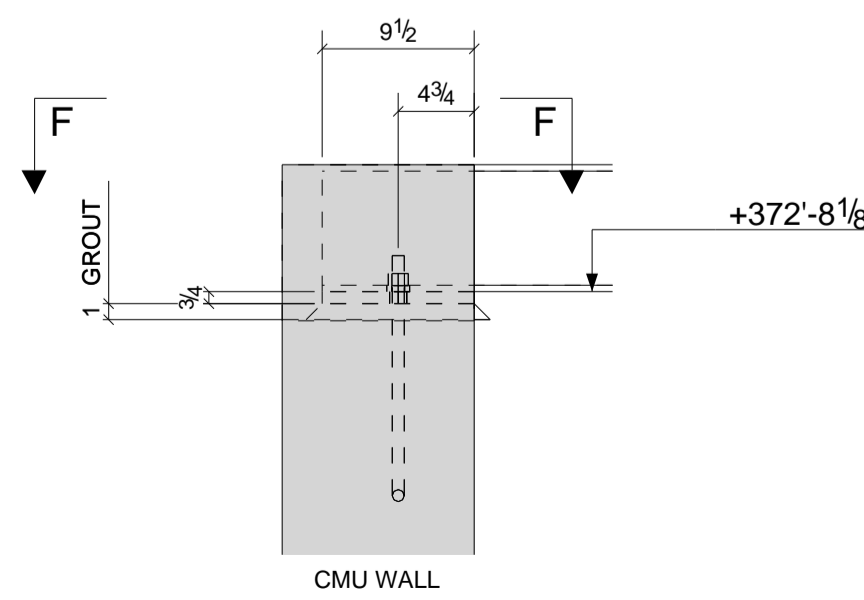

DETAIL C

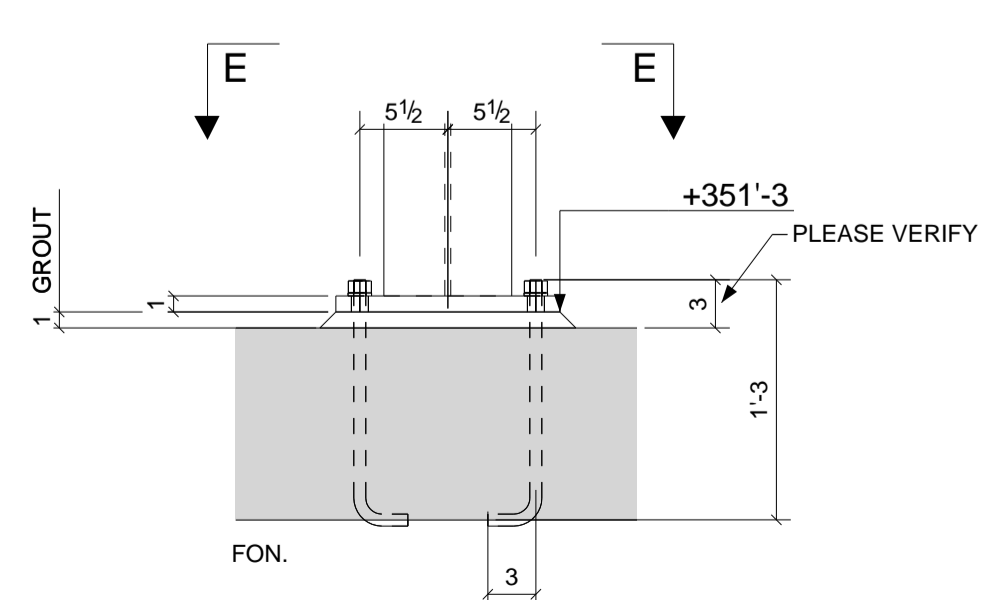

DETAIL B

DATE	NO.	DESCRIPTION	BY
5/12/09	1	For Approval	TMAC
6/04/09	2	For Approval	TMAC
9/30/09	3	For Approval	TMAC
10/09/09	4	For Fabrication	MT

STEEL ASTM	WELDS	OPEN HOLES	BOLTS	PAINT
A992	E70xx LH	1 3/16"	A325-N-ST	PER SPECS

PROJECT NAME	LOCATION	CONTRACTOR	ARCHITECT
LITITZ W.W.T.P.	WARWICK TWP.-LANCASTER CO., PA	PLEASANT MOUNT WELDING, INC.	ENTECH ENGINEERING,

**A S P Services Inc**  
 Selinsgrove, PA 17870  
 (570) 374-5333 FAX (570) 374-5335 asp-services-inc.com

DATE: 05/12/2009  
 DRAWN BY: TMAC  
 JOB No: 17-052-9  
 DRG No: E2-1





GRID LOCATION	BOTTOM ELEVATION
1/C	351'-3"

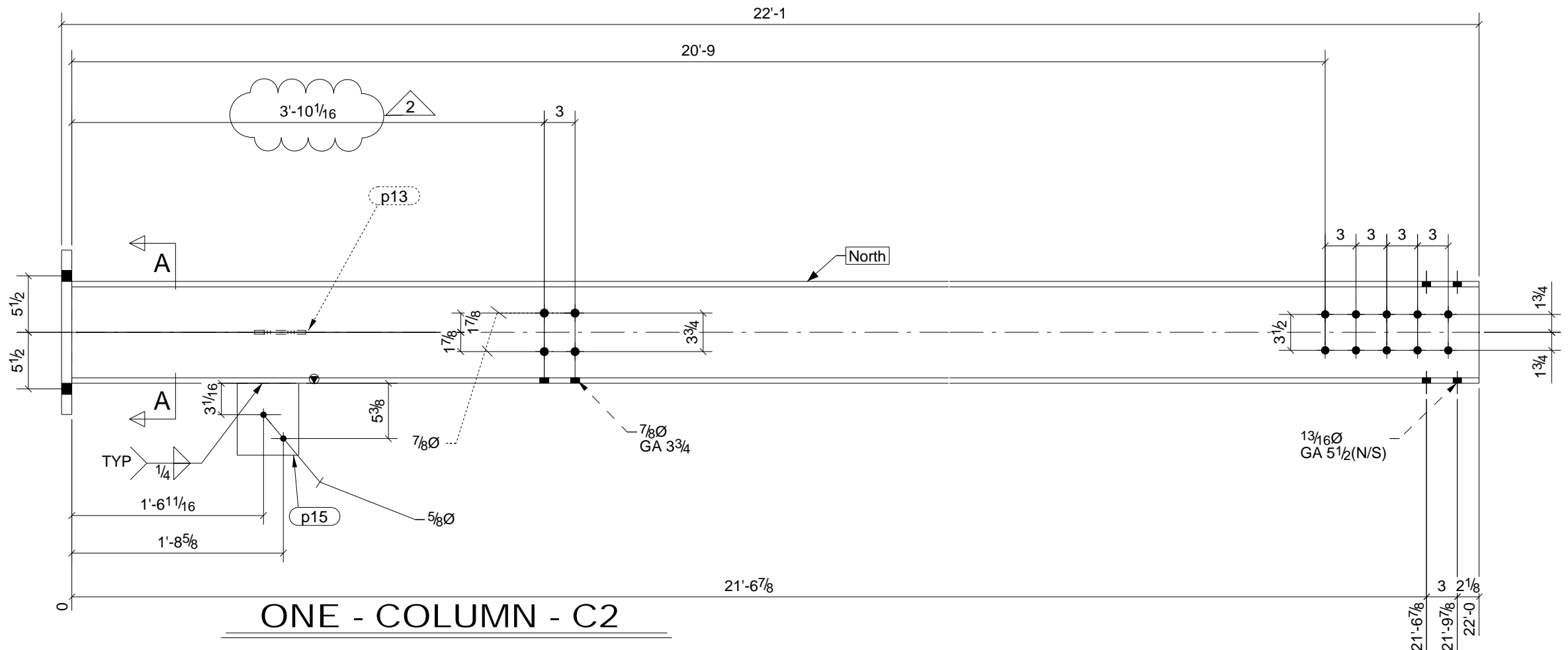
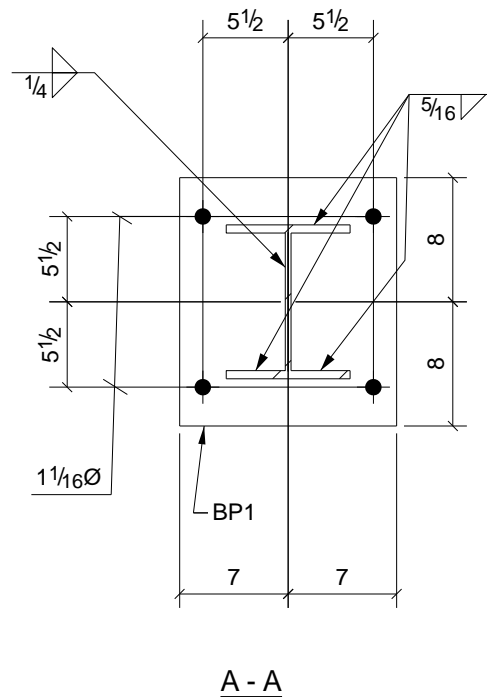
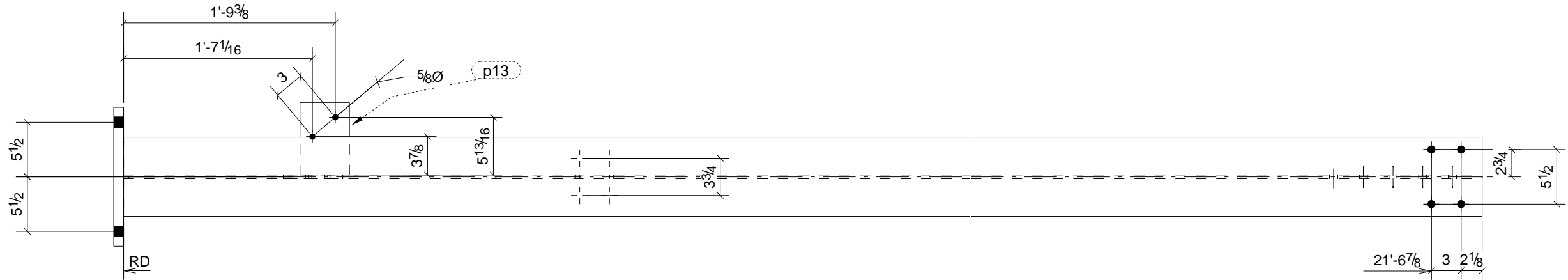

### BILL OF MATERIAL

Qty Ea.	Qty Tot	Piece Mark	Description	Length	Weight Total	Remarks	Adv Mill #	Steel Grade
	1	C2	COLUMN					
1	1		W10X39	22'-0"	861	SQ-2		A992
1	1	BP1	PL1"X14"	1'-4"	64			A36
1	1	p13	FL3/8"X5"	0'-7 5/16"	4			A36
1	1	p15	FL3/8"X6"	0'-7"	4			A36

STEEL ASTM	A992	UNO	PROJECT NAME
ELECTRODES	E70xx LH	UNO	LITITZ W.W.T.P.
WELDS	1/4 BUTT/FILLET	UNO	WARWICK TWP.-LANCASTER CO., PA
OPEN HOLES	13/16"	UNO	PLEASANT MOUNT WELDING, INC.
BOLTS	3/4"Ø A325-N-ST	UNO	ARCHITECT
PAINT	PER SPECS	UNO	ENTECH ENGINEERING, INC.

10/19/09	2	Corrected Hole Dim	MT
10/14/09	1	For Fabrication - Customer Changes	MT
DATE	NO.	DESCRIPTION	BY
<b>A S P Services Inc</b> Selinsgrove, PA 17870 (570) 374-5333 FAX (570) 374-5335 aspsservicesinc.com			
DESCRIPTION	DATE	JOB No.	
COLUMN	10/09/2009	17-052-9	
DRAWN BY		DRG No.	
		C2	



GRID LOCATION	BOTTOM ELEVATION
0/C	357'-4"
0/B	357'-4"

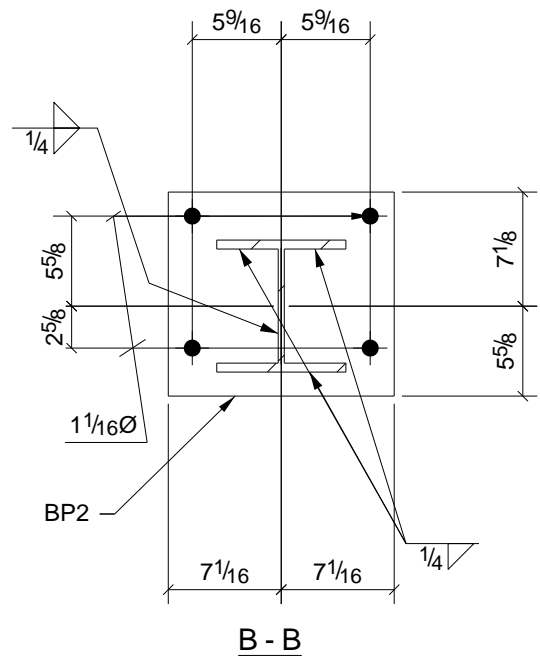
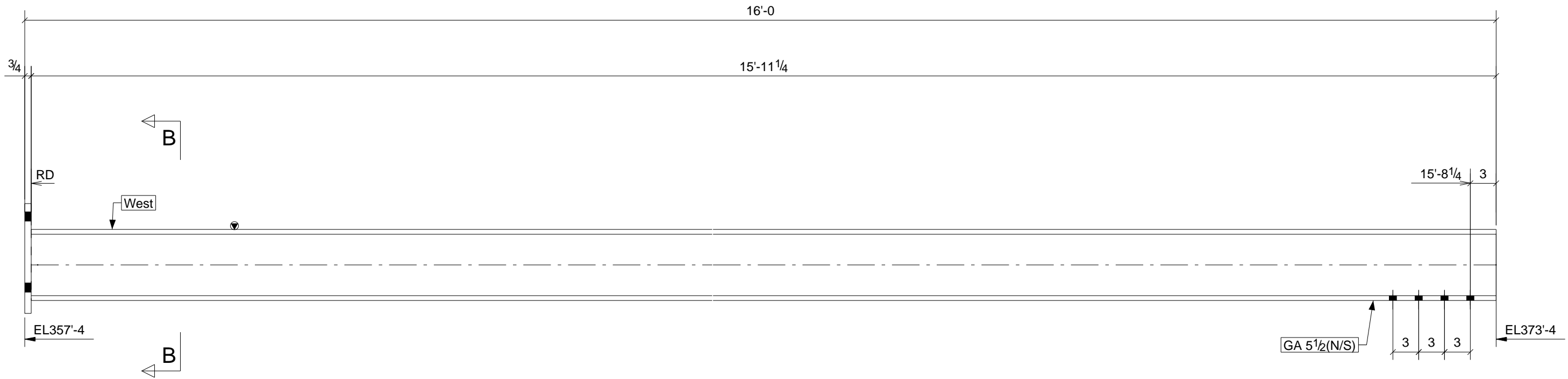

## 2 - COLUMNS - C10

DATE	NO.	DESCRIPTION	BY
9/30/09	△C	For Approval	TMAC
6/04/09	△B	For Approval	TMAC
5/12/09	△A	For Approval	TMAC
10/09/09	△D	For Fabrication	MT

BILL OF MATERIAL								STEEL ASTM	A992	UNO	PROJECT NAME	<b>A S P Services Inc</b> Selinsgrove, PA 17870 (570) 374-5333 FAX (570) 374-5335 asp-services-inc.com				
Qty Ea.	Qty Tot	Piece Mark	Description	Length	Weight Total	Remarks	Adv Mill #	Steel Grade	ELECTRODES	E70xx LH	UNO				LOCATION	WARWICK TWP.-LANCASTER CO., PA
	2	C10	COLUMNS						WELDS	1/4 BUTT/FILLET	UNO				CONTRACTOR	PLEASANT MOUNT WELDING, INC.
	2		W8X40	15'-11 1/4"	1269	SQ-2		A992	OPEN HOLES	13/16"	UNO				ARCHITECT	ENTECH ENGINEERING, INC.
	1	BP2	PL3/4"X12 3/4"	1'-2 1/8"	77			A36	BOLTS	3/4"Ø A325-N-ST	UNO					
									PAINT	PER SPECS	UNO					

DESCRIPTION	DATE	JOB No.
COLUMN	05/12/2009	17-052-9
	DRAWN BY TMAC	DRG No. C10

GRID LOCATION	BOTTOM ELEVATION
1/B	351'-3"

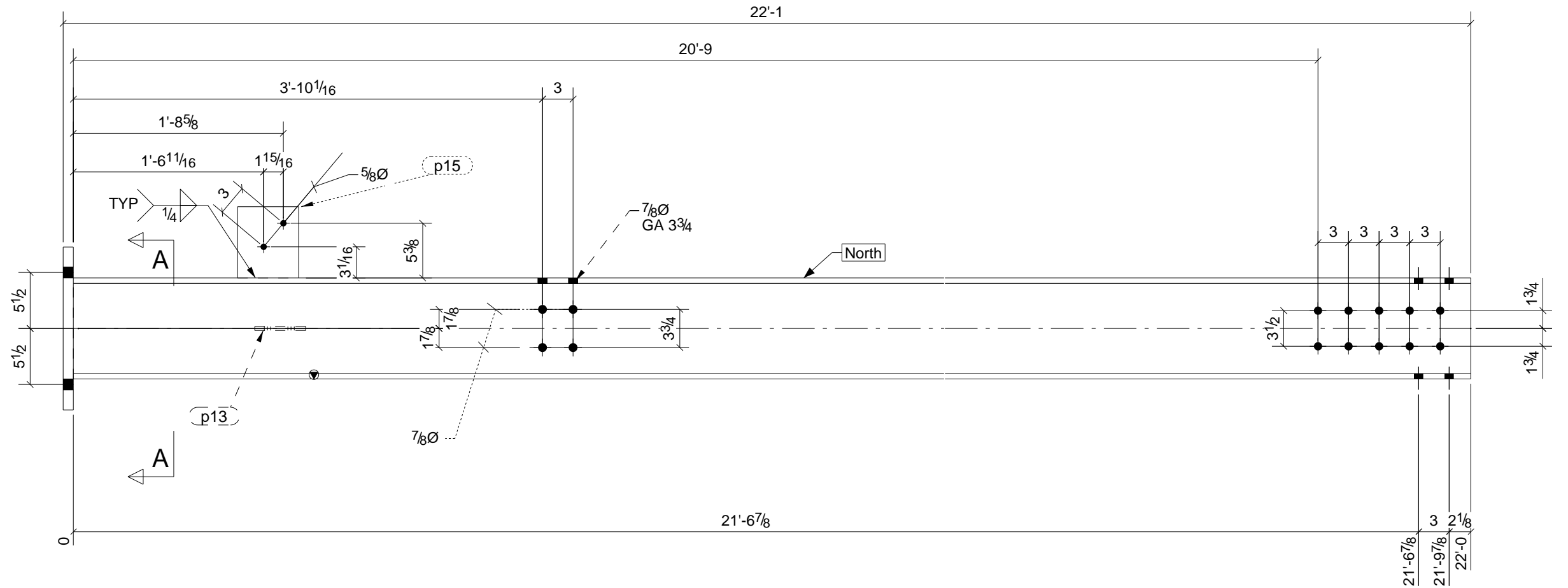
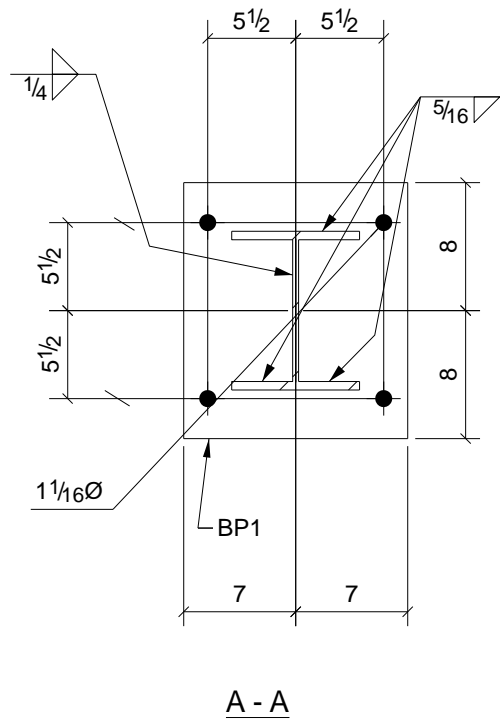
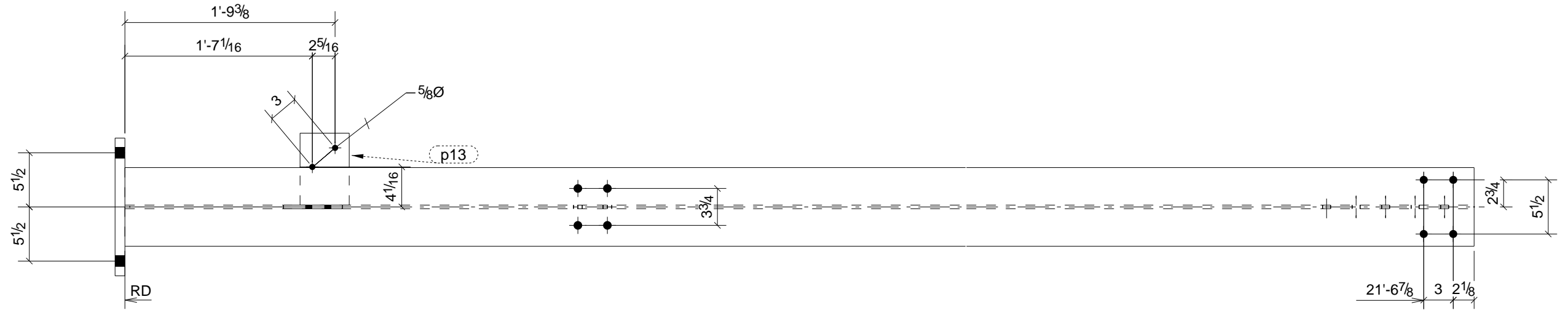

**ONE - COLUMN - C12**

**BILL OF MATERIAL**

Qty Ea.	Qty Tot	Piece Mark	Description	Length	Weight Total	Remarks	Adv Mill #	Steel Grade
	1	C12	COLUMN					
1	1		W10X39	22'-0"	861	SQ-2		A992
1	1	BP1	PL1"X14"	1'-4"	64			A36
1	1	p13	FL3/8"X5"	0'-7 5/16"	4			A36
1	1	p15	FL3/8"X6"	0'-7"	4			A36

STEEL ASTM	A992	UNO	PROJECT NAME	LITITZ W.W.T.P.
ELECTRODES	E70xx LH	UNO	LOCATION	WARWICK TWP.-LANCASTER CO., PA
WELDS	1/4 BUTT/FILLET	UNO	CONTRACTOR	PLEASANT MOUNT WELDING, INC.
OPEN HOLES	13/16"	UNO	ARCHITECT	ENTECH ENGINEERING, INC.
BOLTS	3/4"Ø A325-N-ST	UNO		
PAINT	PER SPECS	UNO		

9/30/09	△C	For Approval	TMAC
6/04/09	△B	For Approval	TMAC
5/12/09	△A	For Approval	TMAC
10/14/09	△1	For Fabrication - Customer Changes	MT
10/09/09	△0	For Fabrication	MT
DATE	NO.	DESCRIPTION	BY

**A S P Services Inc**  
Selinsgrove, PA 17870  
(570) 374-5333 FAX (570) 374-5335 asp-services-inc.com

DESCRIPTION	DATE	JOB No.
COLUMN	05/12/2009	17-052-9
	DRAWN BY	DRG No.
	TMAC	C12

GRID LOCATION	BOTTOM ELEVATION
3/C	357'-4"
3/B	357'-4"

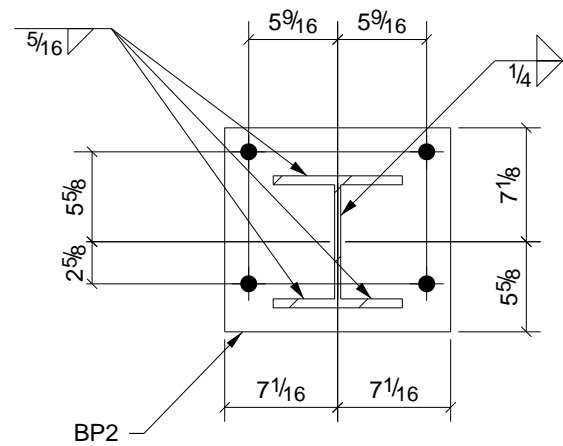

B - B



## 2 - COLUMNS - C13

9/30/09	△C	For Approval	TMAC
6/04/09	△B	For Approval	TMAC
5/12/09	△A	For Approval	TMAC
10/09/09	△D	For Fabrication	MT
DATE	NO.	DESCRIPTION	BY

### BILL OF MATERIAL

Qty Ea.	Qty Tot	Piece Mark	Description	Length	Weight Total	Remarks	Adv Mill #	Steel Grade
	2	C13	COLUMNS					
2	2		W8X40	15'-11 1/4"	1269	SQ-2		A992
1	2	BP2	PL3/4"X12 3/4"	1'-2 1/8"	77			A36

STEEL ASTM	A992	UNO
ELECTRODES	E70xx LH	UNO
WELDS	1/4 BUTT/FILLET	UNO
OPEN HOLES	13/16"	UNO
BOLTS	3/4"Ø A325-N-ST	UNO
PAINT	PER SPECS	UNO

PROJECT NAME	LITITZ W.W.T.P.
LOCATION	WARWICK TWP.-LANCASTER CO., PA
CONTRACTOR	PLEASANT MOUNT WELDING, INC.
ARCHITECT	ENTECH ENGINEERING, INC.

<b>A S P Services Inc</b>	
Selinsgrove, PA 17870	
(570) 374-5333 FAX (570) 374-5335 asp-servicesinc.com	
DESCRIPTION	COLUMN
DATE	05/12/2009
DRAWN BY	TMAC
JOB No.	17-052-9
DRG No.	C13



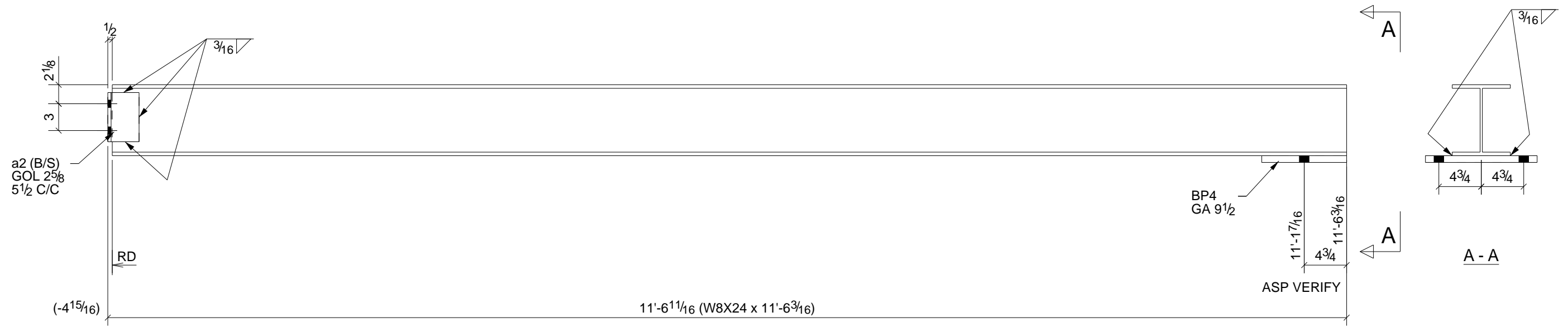

## 2 - BEAMS - B20

9/30/09	△C	For Approval	TMAC
6/04/09	△B	For Approval	TMAC
5/12/09	△A	For Approval	TMAC
10/09/09	△D	For Fabrication	MT
DATE	NO.	DESCRIPTION	BY

### BILL OF MATERIAL

Qty Ea.	Qty Tot	Piece Mark	Description	Length	Weight Total	Remarks	Adv Mill #	Steel Grade
	2	B20	BEAMS					
2	2		W8X24	11'-6 3/16"	555	SQ-2		A992
1	2	BP4	FL3/4"X9 1/2"	1'-0 1/2"	51			A36
2	4	a2	L4X3-1/2X3/8	0'-5 1/2"	17			A36

STEEL ASTM	A992	UNO	PROJECT NAME
ELECTRODES	E70xx LH	UNO	LITITZ W.W.T.P.
WELDS	1/4 BUTT/FILLET	UNO	WARWICK TWP.-LANCASTER CO., PA
OPEN HOLES	13/16"	UNO	PLEASANT MOUNT WELDING, INC.
BOLTS	3/4"Ø A325-N-ST	UNO	ENTECH ENGINEERING, INC.
PAINT	PER SPECS	UNO	

<b>A S P Services Inc</b> Selinsgrove, PA 17870 (570) 374-5333 FAX (570) 374-5335 asp-servicesinc.com	
DESCRIPTION <b>BEAM</b>	DATE 05/12/2009 DRAWN BY TMAC
JOB No. <b>17-052-9</b>	DRG No. <b>B20</b>

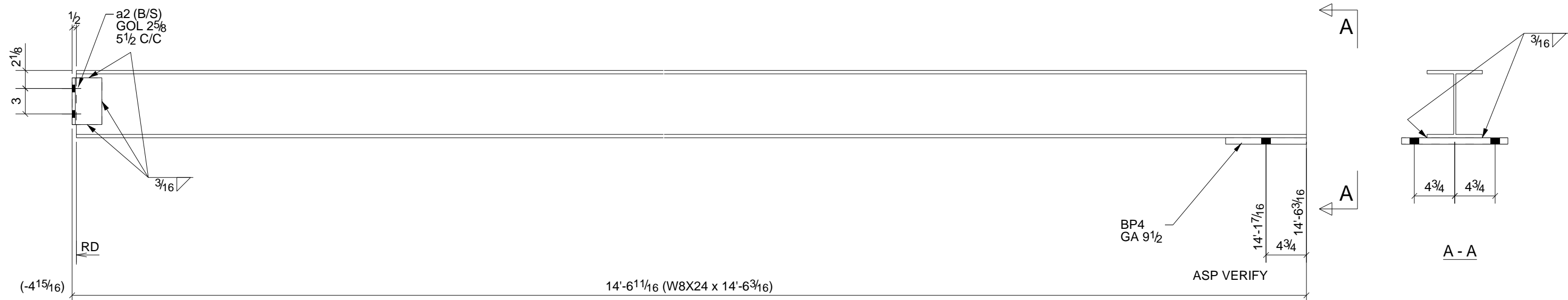

**2 - BEAMS - B21**

**BILL OF MATERIAL**

Qty Ea.	Qty Tot	Piece Mark	Description	Length	Weight Total	Remarks	Adv Mill #	Steel Grade
	2	B21	BEAMS					
2	2		W8X24	14'-6 3/16"	699	SQ-2		A992
1	2	BP4	FL3/4"X9 1/2"	1'-0 1/2"	51			A36
2	4	a2	L4X3-1/2X3/8	0'-5 1/2"	17			A36

STEEL ASTM	A992	UNO
ELECTRODES	E70xx LH	UNO
WELDS	1/4 BUTT/FILLET	UNO
OPEN HOLES	13/16"	UNO
BOLTS	3/4"Ø A325-N-ST	UNO
PAINT	PER SPECS	UNO

PROJECT NAME	LITITZ W.W.T.P.
LOCATION	WARWICK TWP.-LANCASTER CO., PA
CONTRACTOR	PLEASANT MOUNT WELDING, INC.
ARCHITECT	ENTECH ENGINEERING, INC.

9/30/09	△C	For Approval	TMAC
6/04/09	△B	For Approval	TMAC
5/12/09	△A	For Approval	TMAC
10/09/09	△D	For Fabrication	MT
DATE	NO.	DESCRIPTION	BY

DESCRIPTION <b>BEAM</b>		DATE 05/12/2009	JOB No. <b>17-052-9</b>
		DRAWN BY TMAC	DRG No. <b>B21</b>

**A S P Services Inc**  
Selinsgrove, PA 17870  
(570) 374-5333 FAX (570) 374-5335 asp-services-inc.com



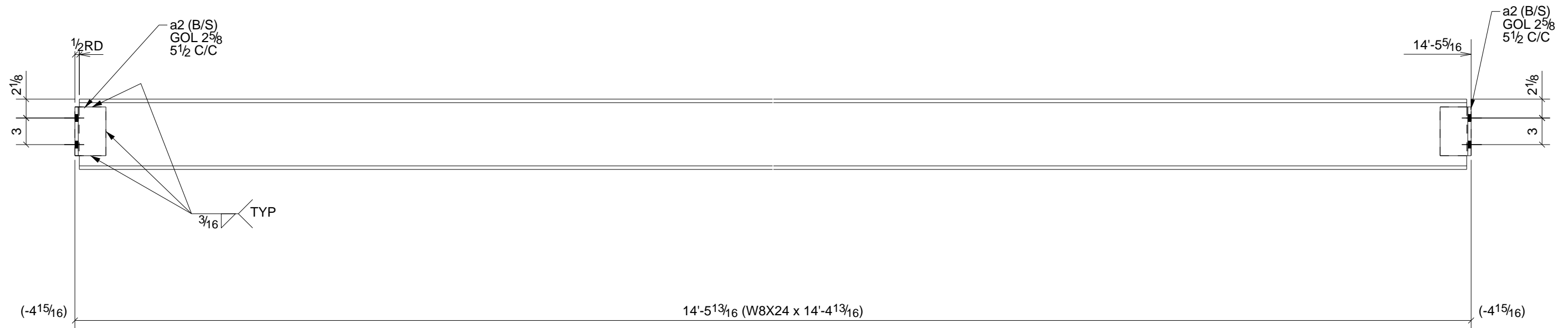

**2 - BEAMS - B22**

9/30/09	△C	For Approval	TMAC
6/04/09	△B	For Approval	TMAC
5/12/09	△A	For Approval	TMAC
10/09/09	△D	For Fabrication	MT
DATE	NO.	DESCRIPTION	BY

**BILL OF MATERIAL**

Qty Ea.	Qty Tot	Piece Mark	Description	Length	Weight Total	Remarks	Adv Mill #	Steel Grade
	2	B22	BEAMS					
2	2		W8X24	14'-4 13/16"	694	SQ-2		A992
4	8	a2	L4X3-1/2X3/8	0'-5 1/2"	33			A36

STEEL ASTM	A992	UNO
ELECTRODES	E70xx LH	UNO
WELDS	1/4 BUTT/FILLET	UNO
OPEN HOLES	13/16"	UNO
BOLTS	3/4"Ø A325-N-ST	UNO
PAINT	PER SPECS	UNO

PROJECT NAME	LITITZ W.W.T.P.
LOCATION	WARWICK TWP.-LANCASTER CO., PA
CONTRACTOR	PLEASANT MOUNT WELDING, INC.
ARCHITECT	ENTECH ENGINEERING, INC.

<b>A S P Services Inc</b> Selinsgrove, PA 17870 (570) 374-5333 FAX (570) 374-5335 asp-servicesinc.com		
DESCRIPTION	DATE	JOB No.
BEAM	05/12/2009	17-052-9
	DRAWN BY	DRG No.
	TMAC	B22

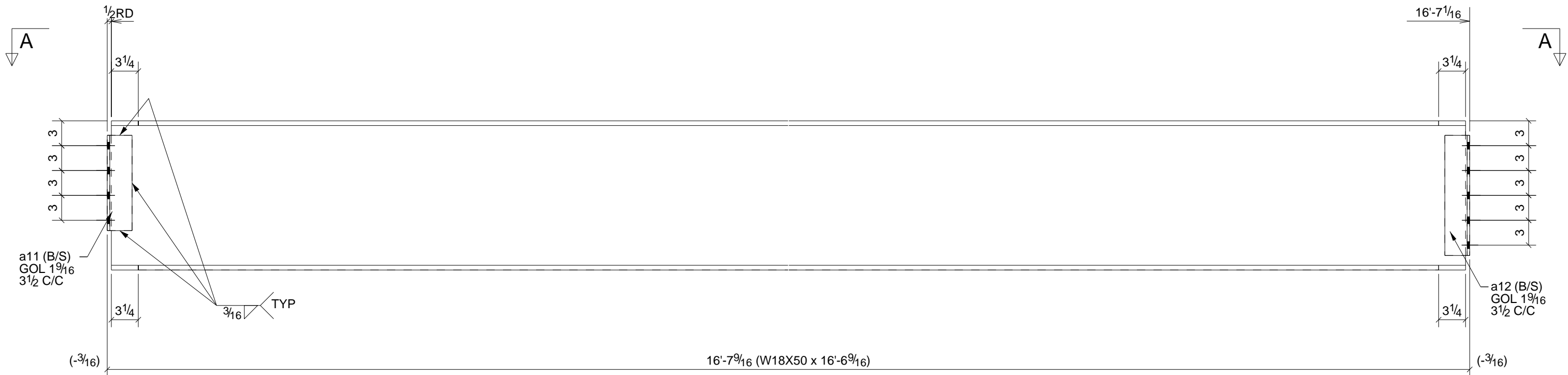
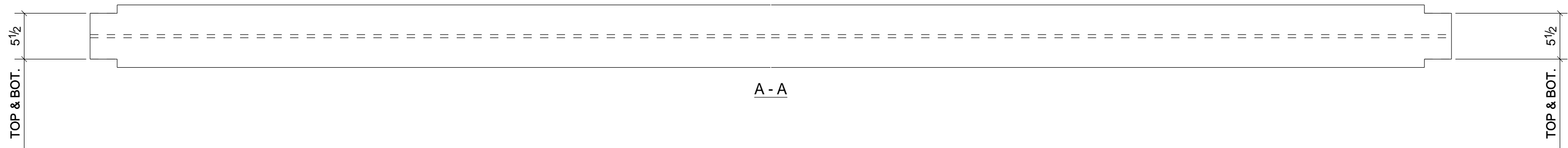

## 2 - BEAMS - B23

9/30/09	△C	For Approval	TMAC
6/04/09	△B	For Approval	TMAC
5/12/09	△A	For Approval	TMAC
10/09/09	△D	For Fabrication	MT
DATE	NO.	DESCRIPTION	BY

### BILL OF MATERIAL

Qty Ea.	Qty Tot	Piece Mark	Description	Length	Weight Total	Remarks	Adv Mill #	Steel Grade
	2	B23	BEAMS					
2	2		W18X50	16'-6 9/16"	1656	SQ-2		A992
2	4	a11	L3X3X5/16	0'-11 1/2"	23			A36
2	4	a12	L3X3X5/16	1'-2 1/2"	29			A36

STEEL ASTM	A992	UNO	PROJECT NAME	LITITZ W.W.T.P.
ELECTRODES	E70xx LH	UNO	LOCATION	WARWICK TWP.-LANCASTER CO., PA
WELDS	1/4 BUTT/FILLET	UNO	CONTRACTOR	PLEASANT MOUNT WELDING, INC.
OPEN HOLES	13/16"	UNO	ARCHITECT	ENTECH ENGINEERING, INC.
BOLTS	3/4"Ø A325-N-ST	UNO		
PAINT	PER SPECS	UNO		

**A S P Services Inc**  
 Selinsgrove, PA 17870  
 (570) 374-5333 FAX (570) 374-5335 asp-services-inc.com

DESCRIPTION	DATE	JOB No.
BEAM	05/12/2009	17-052-9
	DRAWN BY	DRG No.
	TMAC	B23

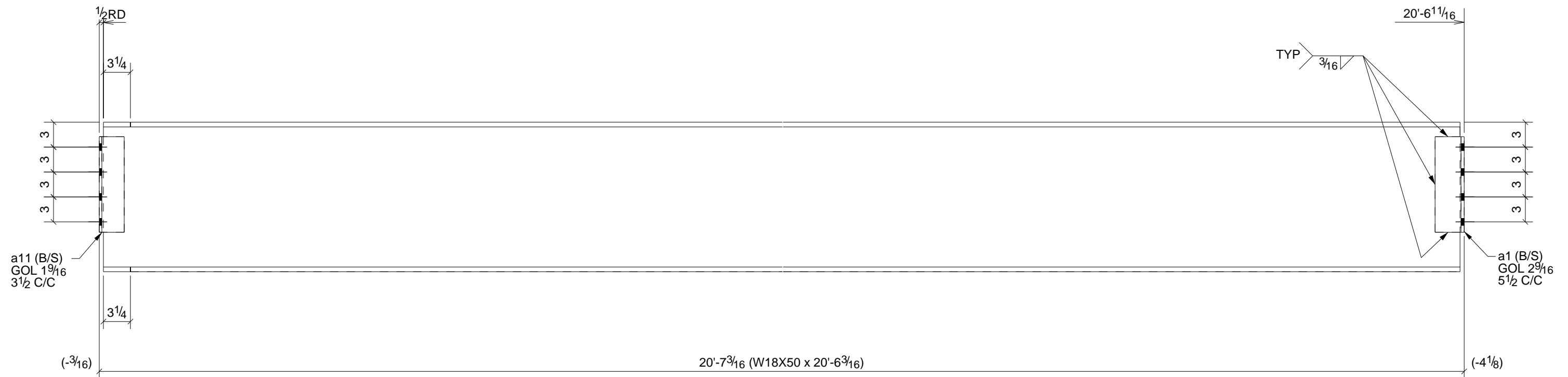

## 2 - BEAMS - B24

### BILL OF MATERIAL

Qty Ea.	Qty Tot	Piece Mark	Description	Length	Weight Total	Remarks	Adv Mill #	Steel Grade
	2	B24	BEAMS					
2	2		W18X50	20'-6 3/16"	2053	SQ-2		A992
2	4	a1	L4X3-1/2X3/8	0'-11 1/2"	35			A36
2	4	a11	L3X3X5/16	0'-11 1/2"	23			A36

STEEL ASTM	A992	UNO
ELECTRODES	E70xx LH	UNO
WELDS	1/4 BUTT/FILLET	UNO
OPEN HOLES	13/16"	UNO
BOLTS	3/4"Ø A325-N-ST	UNO
PAINT	PER SPECS	UNO

PROJECT NAME	LITITZ W.W.T.P.
LOCATION	WARWICK TWP.-LANCASTER CO., PA
CONTRACTOR	PLEASANT MOUNT WELDING, INC.
ARCHITECT	ENTECH ENGINEERING, INC.

6/04/09	△ <sub>B</sub>	For Approval	TMAC
5/12/09	△ <sub>A</sub>	For Approval	TMAC
10/09/09	△ <sub>0</sub>	For Fabrication	MT
DATE	NO.	DESCRIPTION	BY
<b>A S P Services Inc</b> Selinsgrove, PA 17870 (570) 374-5333 FAX (570) 374-5335 asp-services-inc.com			
DESCRIPTION	DATE	JOB No.	
BEAM	05/12/2009	17-052-9	
	DRAWN BY	DRG No.	
	TMAC	B24	

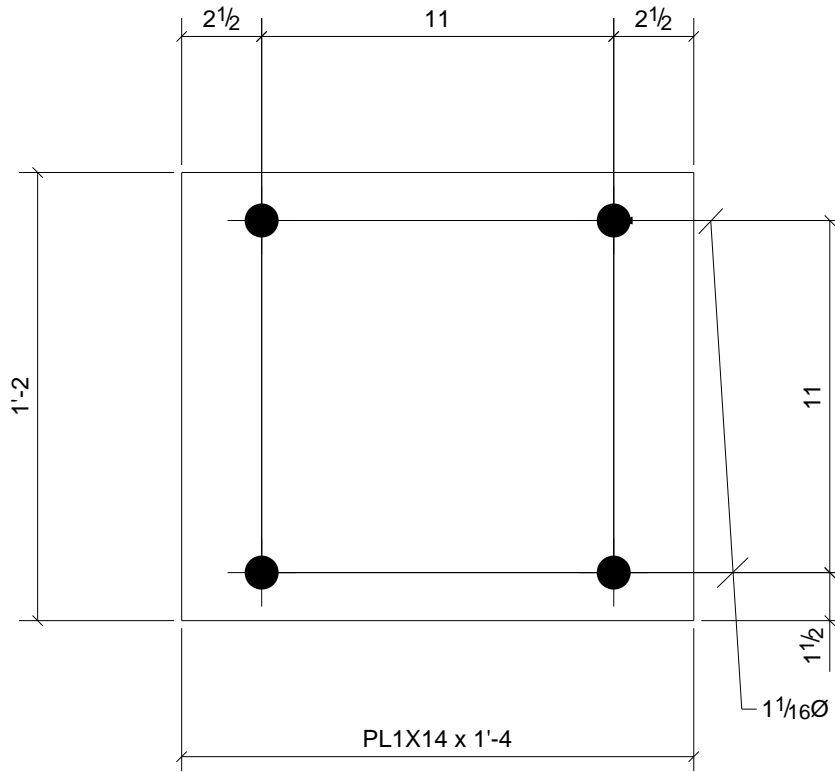

2	C1
2	C12
Qty.	In Assembly

4	BP1	PL1"X14"	1'-4"		A36
Qty.	Mark	Size	Length	Comments	Grade

PROJECT NAME <b>LITITZ W.W.T.P.</b>		<b>A S P Services Inc</b> Selinsgrove, PA 17870 (570) 374-5333 FAX (570) 374-5335 <a href="http://asp-servicesinc.com">asp-servicesinc.com</a>			
LOCATION <b>WARWICK TWP.-LANCASTER CO., PA</b>					
CUSTOMER <b>PLEASANT MOUNT WELDING, INC.</b>		DESCRIPTION <b>PLATE</b>	DATE <b>09/30/2009</b>	JOB No. <b>17-052-9</b>	
ARCHITECT <b>ENTECH ENGINEERING, INC.</b>			DRAWN BY	DRG No. <b>BP1</b>	

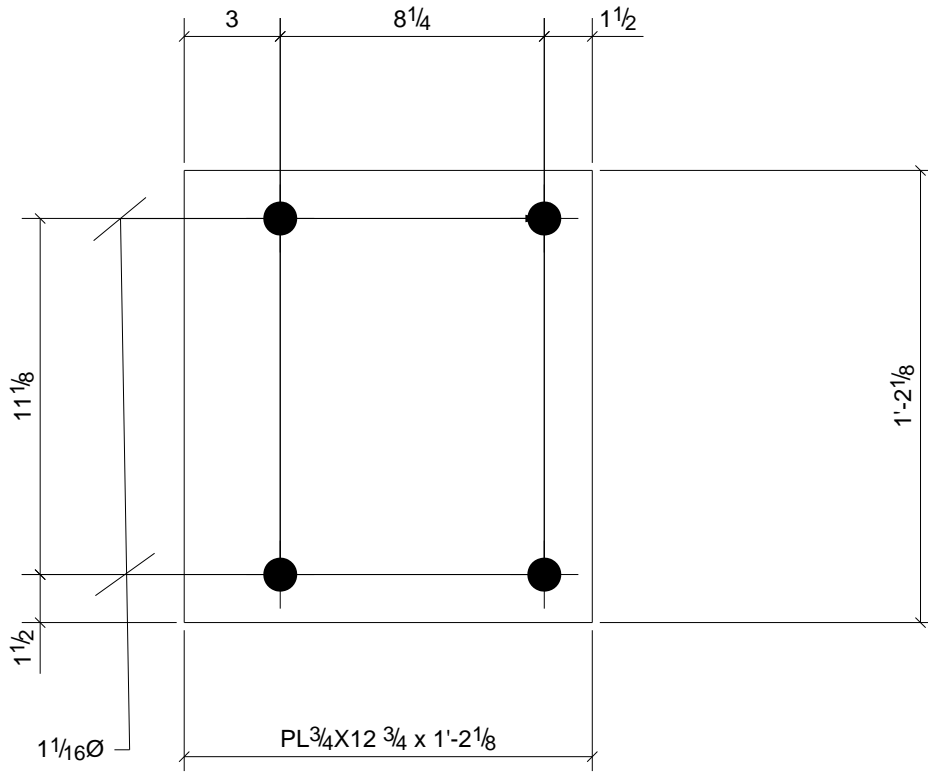

2	C10
2	C13
Qty.	In Assembly

4	BP2	PL3/4"X12 3/4"	1'-2 1/8"		A36
Qty.	Mark	Size	Length	Comments	Grade

PROJECT NAME <b>LITITZ W.W.T.P.</b>		<b>A S P Services Inc</b> Selinsgrove, PA 17870 (570) 374-5333 FAX (570) 374-5335 <a href="http://aspservicesinc.co">aspservicesinc.co</a>			
LOCATION <b>WARWICK TWP.-LANCASTER CO., PA</b>					
CUSTOMER <b>PLEASANT MOUNT WELDING, INC.</b>		DESCRIPTION <b>PLATE</b>	DATE <b>09/30/2009</b>	JOB No. <b>17-052-9</b>	
ARCHITECT <b>ENTECH ENGINEERING, INC.</b>			DRAWN BY	DRG No. <b>BP2</b>	

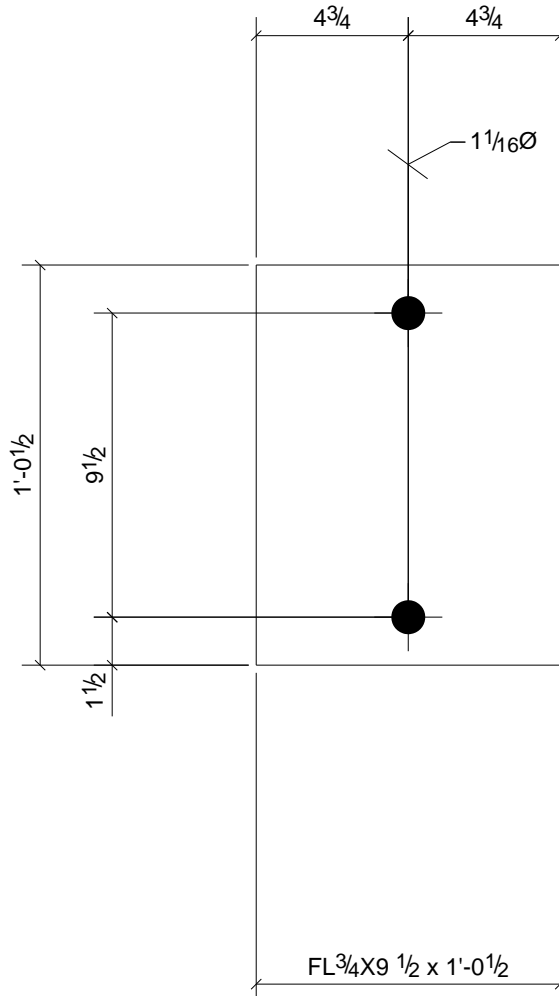

2	B20
2	B21
Qty.	In Assembly

4	BP4	FL3/4"X9 1/2"	1'-0 1/2"		A36
Qty.	Mark	Size	Length	Comments	Grade

PROJECT NAME <b>LITITZ W.W.T.P.</b>	<b>A S P Services Inc</b> Selinsgrove, PA 17870 (570) 374-5333 FAX (570) 374-5335 <a href="http://aspservicesinc.co">aspservicesinc.co</a>			
LOCATION <b>WARWICK TWP.-LANCASTER CO., PA</b>				
CUSTOMER <b>PLEASANT MOUNT WELDING, INC.</b>	DESCRIPTION <b>PLATE</b>	DATE <b>09/30/2009</b>	JOB No. <b>17-052-9</b>	
ARCHITECT <b>ENTECH ENGINEERING, INC.</b>		DRAWN BY <b>TMAC</b>	DRG No. <b>BP4</b>	

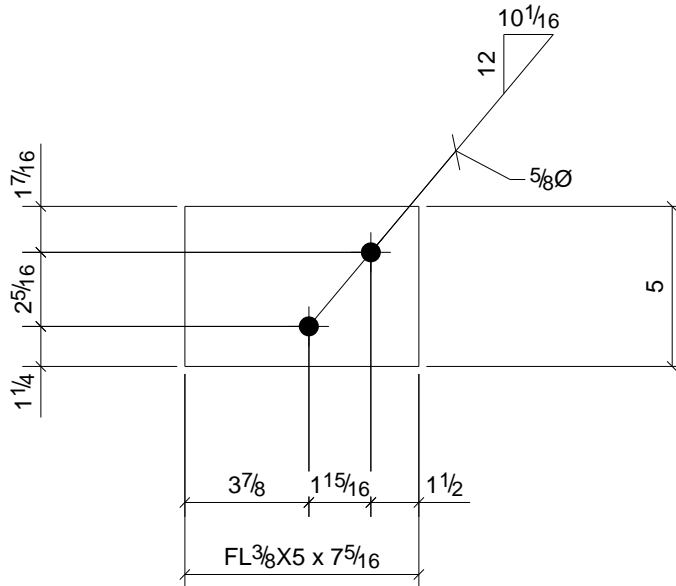

2	C1
2	C12
Qty.	In Assembly

4	p13	FL3/8"X5"	0'-7 5/16"		A36
Qty.	Mark	Size	Length	Comments	Grade

PROJECT NAME <b>LITITZ W.W.T.P.</b>		<b>A S P Services Inc</b> Selinsgrove, PA 17870 (570) 374-5333 FAX (570) 374-5335 asp-servicesinc.co			
LOCATION <b>WARWICK TWP.-LANCASTER CO., PA</b>					
CUSTOMER <b>PLEASANT MOUNT WELDING, INC.</b>		DESCRIPTION <b>PLATE</b>	DATE <b>10/09/2009</b>	JOB No. <b>17-052-9</b>	
ARCHITECT <b>ENTECH ENGINEERING, INC.</b>			DRAWN BY	DRG No. <b>p13</b>	

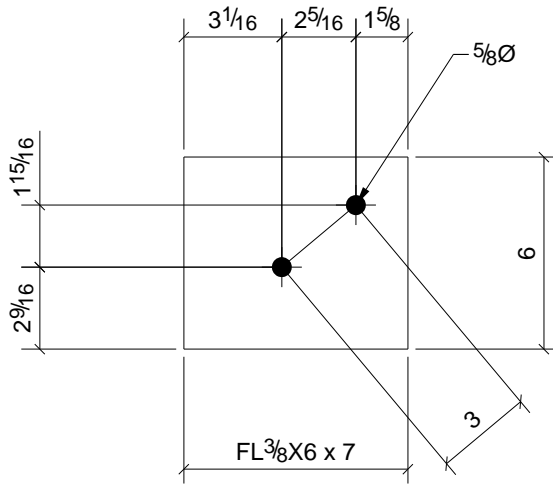

1	C1
1	C2
1	C3
1	C12
Qty.	In Assembly

4	p15	FL3/8"X6"	0'-7"		A36
Qty.	Mark	Size	Length	Comments	Grade

PROJECT NAME <b>LITITZ W.W.T.P.</b>	<b>A S P Services Inc</b> Selinsgrove, PA 17870 (570) 374-5333 FAX (570) 374-5335 <a href="http://aspservicesinc.co">aspservicesinc.co</a>				
LOCATION <b>WARWICK TWP.-LANCASTER CO., PA</b>					
CUSTOMER <b>PLEASANT MOUNT WELDING, INC.</b>					
ARCHITECT <b>ENTECH ENGINEERING, INC.</b>	DESCRIPTION <b>PLATE</b>	DATE <b>10/09/2009</b>	JOB No. <b>17-052-9</b>		
		DRAWN BY	DRG No. <b>p15</b>		



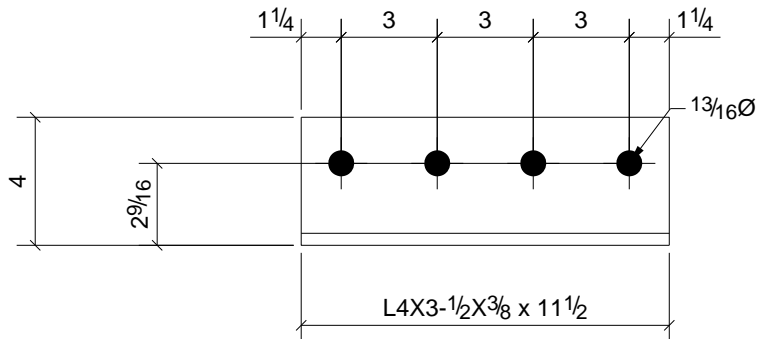

4	B19
4	B24
Qty.	In Assembly

8	a1	L4X3-1/2X3/8	0'-11 1/2"		A36
Qty.	Mark	Size	Length	Comments	Grade

PROJECT NAME <b>LITITZ W.W.T.P.</b>		<b>A S P Services Inc</b> Selinsgrove, PA 17870 (570) 374-5333 FAX (570) 374-5335 aspervicesinc.co			
LOCATION <b>WARWICK TWP.-LANCASTER CO., PA</b>					
CUSTOMER <b>PLEASANT MOUNT WELDING, INC.</b>		DESCRIPTION <b>ANGLE</b>	DATE <b>06/03/2009</b>	JOB No. <b>17-052-9</b>	
ARCHITECT <b>ENTECH ENGINEERING, INC.</b>			DRAWN BY <b>TMAC</b>	DRG No. <b>a1</b>	

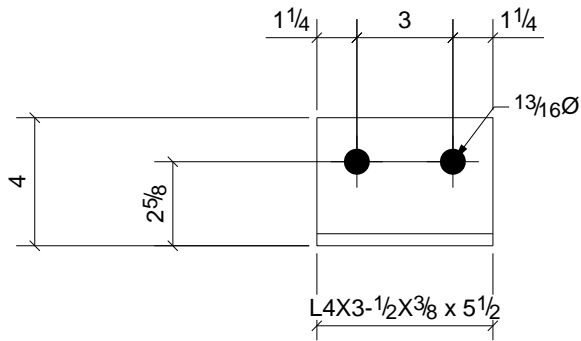

4	B20
4	B21
8	B22
Qty.	In Assembly

16	a2	L4X3-1/2X3/8	0'-5 1/2"		A36
Qty.	Mark	Size	Length	Comments	Grade

PROJECT NAME <b>LITITZ W.W.T.P.</b>		<b>A S P Services Inc</b> Selinsgrove, PA 17870 (570) 374-5333 FAX (570) 374-5335 aspervicesinc.co			
LOCATION <b>WARWICK TWP.-LANCASTER CO., PA</b>					
CUSTOMER <b>PLEASANT MOUNT WELDING, INC.</b>		DESCRIPTION <b>ANGLE</b>	DATE <b>06/03/2009</b>	JOB No. <b>17-052-9</b>	
ARCHITECT <b>ENTECH ENGINEERING, INC.</b>			DRAWN BY <b>TMAC</b>	DRG No. <b>a2</b>	

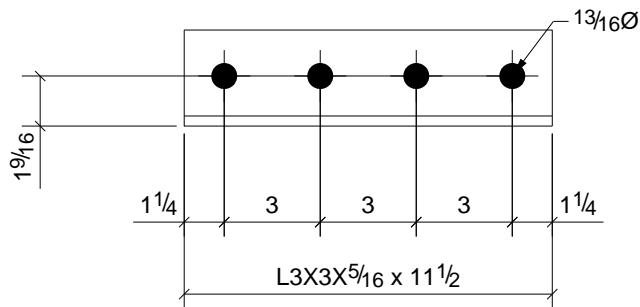

4	B23
4	B24
Qty.	In Assembly

8	a11	L3X3X5/16	0'-11 1/2"		A36
Qty.	Mark	Size	Length	Comments	Grade

PROJECT NAME <b>LITITZ W.W.T.P.</b>	<b>A S P Services Inc</b> Selinsgrove, PA 17870 (570) 374-5333 FAX (570) 374-5335 asp-servicesinc.co			
LOCATION <b>WARWICK TWP.-LANCASTER CO., PA</b>				
CUSTOMER <b>PLEASANT MOUNT WELDING, INC.</b>	DESCRIPTION <b>ANGLE</b>	DATE <b>06/03/2009</b>	JOB No. <b>17-052-9</b>	
ARCHITECT <b>ENTECH ENGINEERING, INC.</b>		DRAWN BY <b>TMAC</b>	DRG No. <b>a11</b>	

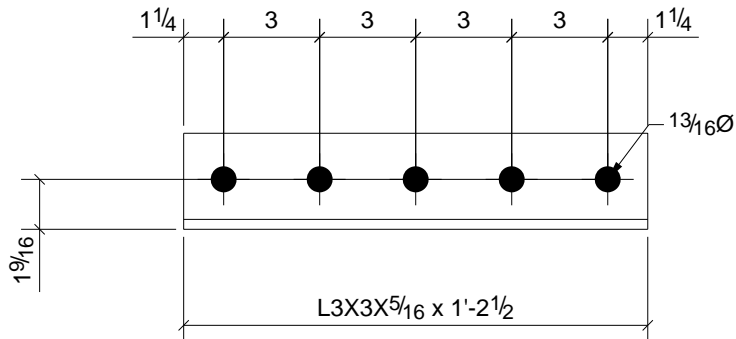

4	B19
4	B23
Qty.	In Assembly

8	a12	L3X3X5/16	1'-2 1/2"		A36
Qty.	Mark	Size	Length	Comments	Grade

PROJECT NAME <b>LITITZ W.W.T.P.</b>	<b>A S P Services Inc</b> Selinsgrove, PA 17870 (570) 374-5333 FAX (570) 374-5335 aspervicesinc.co			
LOCATION <b>WARWICK TWP.-LANCASTER CO., PA</b>				
CUSTOMER <b>PLEASANT MOUNT WELDING, INC.</b>	DESCRIPTION <b>ANGLE</b>	DATE <b>06/03/2009</b>	JOB No. <b>17-052-9</b>	
ARCHITECT <b>ENTECH ENGINEERING, INC.</b>		DRAWN BY <b>TMAC</b>	DRG No. <b>a12</b>	